

Nikon

DIGITAL CAMERA

1 v3

User's Manual

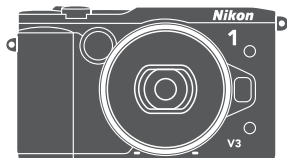

En



Nikon Manual Viewer 2

Use the Nikon Manual Viewer 2 app to view manuals anytime, anywhere on your smartphone or tablet.

Table of Contents

Getting the Most from Your Camera	iii
About This Manual	iv
The Reference Manual	v
For Your Safety.....	vi
Notices.....	ix
Wireless	xiv
Introduction	1
<hr/>	
The Camera and Accessories	1
Parts of the Camera	2
Using the Vari-Angle Monitor	13
Using the Touch Screen.....	15
First Steps.....	20
Attaching a Grip and Electronic Viewfinder	27
Taking and Viewing Photographs	31
<hr/>	
Point-and-Shoot Photography (Auto Mode)	31
Viewing Photographs	35
Deleting Pictures	36
Live Image Control.....	37
Choosing a Creative Mode.....	39
Choosing a Mode That Matches the Subject or Situation.....	40
The Creative Palette	41
HDR	42
Easy Panorama	43
Selective Color.....	46
Cross Process	47
Recording and Viewing Movies	48
<hr/>	
Recording Movies	48
Taking Photographs During Movie Recording.....	52
Viewing Movies.....	53
Deleting Movies.....	54

P, S, A, and M Modes	56
P Programmed Auto	56
S Shutter-Priority Auto	57
A Aperture-Priority Auto.....	58
M Manual	59
Other Shooting Modes	61
☑ Choosing the Moment (Best Moment Capture)	61
Choosing a Shot Manually (Active Selection).....	61
Choosing Your Moment (Slow View).....	65
Letting the Camera Choose the Moment (Smart Photo Selector).....	67
☑ Combining Photos with Brief Movie Vignettes (Motion Snapshot Mode)	71
Viewing Motion Snapshots	74
Deleting Motion Snapshots	74
More on Photography	75
Continuous Mode.....	75
Self-Timer Modes	77
Remote Control Photography	79
The Built-in Flash.....	81
Tap Shooting Options	85
Wi-Fi	88
What Wi-Fi Can Do for You	88
Accessing the Camera	89
WPS (Android Only)	90
PIN Entry (Android Only).....	91
SSID (Android and iOS).....	92
Uploading Pictures to a Smart Device	94
Menu Options	98

Connecting to a Computer	103
Installing the Supplied Software	103
System Requirements.....	104
Viewing and Editing Pictures on a Computer	106
Transferring Pictures	106
Viewing Pictures	108
Technical Notes	109
Optional Accessories	109
Approved Memory Cards	111
Storage and Cleaning	112
Storage.....	112
Cleaning.....	112
Caring for the Camera and Battery: Cautions	113
Troubleshooting	118
Battery/Display.....	118
Shooting (All Modes)	119
Movies	120
Tap Shooting Options	120
Playback.....	120
Wi-Fi (Wireless Networks).....	121
Miscellaneous.....	121
Error Messages	122
Specifications	124
Nikon 1 V3 Digital Camera	124
Battery Life.....	134
Index	135

Getting the Most from Your Camera

Take photos with the shutter-release button.

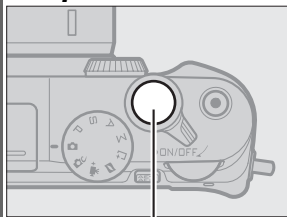

Shutter-release button

See page 7 for more information.

Shoot movies with the movie-record button.

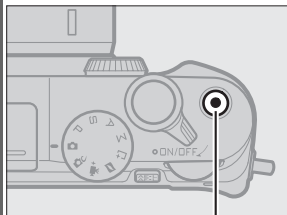

Movie-record button

Movies can be recorded by pressing the movie-record button in auto (📖 31), creative (📖 39), P, S, A, M (📖 56), and advanced movie (📖 48) modes.

About This Manual

For a complete guide to using your digital camera, see the *Reference Manual* (page v). To get the most from your camera, please be sure to read this *User's Manual* thoroughly and keep it where it will be read by all who use the product.

Camera Settings

The explanations in this manual assume that default settings are used.

Symbols and Conventions

To make it easier to find the information you need, the following symbols and conventions are used:



This icon marks cautions; information that should be read before use to prevent damage to the camera.



This icon marks notes; information that should be read before using the camera.



This icon marks references to other pages in this manual.

The lens generally used in this manual for illustrative purposes is a 1 NIKKOR VR 10–30mm f/3.5–5.6 PD-ZOOM.

For Your Safety

Before using the camera for the first time, read the safety instructions in “For Your Safety” (📖 vi–viii) and “Caring for the Camera and Battery: Cautions” (📖 113).

The Reference Manual

For more information on using your Nikon camera, download a pdf copy of the camera *Reference Manual* from the website listed below. The *Reference Manual* can be viewed using Adobe Reader or Adobe Acrobat Reader 5.0 or later.

- 1 On your computer, launch a web browser and open the Nikon manual download site at <http://nikonimglib.com/manual/>
- 2 Navigate to the page for the desired product and download the manual.

Nikon Manual Viewer 2



Install the Nikon Manual Viewer 2 app on your smartphone or tablet to view Nikon digital camera manuals, anytime, anywhere. Nikon Manual Viewer 2 can be downloaded free of charge from the App Store and Google Play. Download of the app and any product manuals requires an Internet connection, for which fees may be levied by your phone or Internet service provider.

For Your Safety

To prevent damage to your Nikon product or injury to yourself or to others, read the following safety precautions in their entirety before using this equipment. Keep these safety instructions where all those who use the product will read them.

The consequences that could result from failure to observe the precautions listed in this section are indicated by the following symbol:



This icon marks warnings. To prevent possible injury, read all warnings before using this Nikon product.

■ ■ ■ WARNINGS

- ⚠ **Keep the sun out of the frame.** Keep the sun well out of the frame when shooting backlit subjects. Sunlight focused into the camera when the sun is in or close to the frame could cause a fire.
- ⚠ **Do not look at the sun through the viewfinder.** Viewing the sun or other strong light source through the viewfinder could cause permanent visual impairment.
- ⚠ **Turn off immediately in the event of malfunction.** Should you notice smoke or an unusual smell coming from the equipment or AC adapter (available separately), unplug the AC adapter and remove the battery immediately, taking care to avoid burns. Continued operation could result in injury. After removing the battery, take the equipment to a Nikon-authorized service center for inspection.
- ⚠ **Do not use in the presence of flammable gas.** Do not use electronic equipment in the presence of flammable gas, as this could result in explosion or fire.
- ⚠ **Keep dry.** Do not immerse in or expose to water or handle with wet hands. Failure to keep the product dry could result in damage to the product, fire, or electric shock, while handling the product with wet hands could result in electric shock.
- ⚠ **Do not disassemble.** Touching the product's internal parts could result in injury. In the event of malfunction, the product should be repaired only by a qualified technician. Should the product break open as the result of a fall or other accident, remove the battery and/or AC adapter and then take the product to a Nikon-authorized service center for inspection.
- ⚠ **Keep out of reach of children.** Failure to observe this precaution could result in injury. In addition, note that small parts constitute a choking hazard. Should a child swallow any part of this equipment, consult a physician immediately.

- ⚠ Do not place the strap around the neck of an infant or child.** Placing the camera strap around the neck of an infant or child could result in strangulation.
- ⚠ Follow the instructions of airline and hospital personnel.** This camera transmits radio frequencies that could interfere with medical equipment or aircraft navigation. Disable the wireless network feature before boarding an aircraft, and turn the camera off during take off and landing. In medical facilities, follow staff instructions regarding the use of wireless devices.
- ⚠ Do not remain in contact with the camera, battery, or charger for extended periods while the devices are on or in use.** Parts of the device become hot. Leaving the device in direct contact with the skin for extended periods may result in low-temperature burns.
- ⚠ Do not leave the product where it will be exposed to extremely high temperatures, such as in an enclosed automobile or in direct sunlight.** Failure to observe this precaution could cause damage or fire.
- ⚠ Do not aim the flash at the operator of a motor vehicle.** Failure to observe this precaution could result in accidents.
- ⚠ Observe caution when using a flash.**
- Using the camera with the flash in close contact with the skin or other objects could cause burns.
 - Using a flash close to the subject's eyes could cause temporary visual impairment. The flash should be no less than one meter (3 ft 4 in.) from the subject. Particular care should be observed when photographing infants.
- ⚠ Avoid contact with liquid crystal.** Should the display break, care should be taken to avoid injury due to broken glass and to prevent the liquid crystal from the display touching the skin or entering the eyes or mouth.
- ⚠ Do not carry tripods with a lens or camera attached.** You could trip or accidentally strike others, resulting in injury.
- ⚠ Observe proper precautions when handling batteries.** Batteries may leak or explode if improperly handled. Observe the following precautions when handling batteries for use in this product:
- Use only batteries approved for use in this equipment.
 - Do not short or disassemble the battery.
 - Be sure the product is off before replacing the battery. If you are using an AC adapter, be sure it is unplugged.
 - Do not attempt to insert the battery upside down or backwards.

- Do not expose the battery to flame or to excessive heat.
- Do not immerse in or expose to water.
- Replace the terminal cover when transporting the battery. Do not transport or store the battery with metal objects such as necklaces or hairpins.
- Batteries are prone to leakage when fully discharged. To avoid damage to the product, be sure to remove the battery when no charge remains.
- When the battery is not in use, attach the terminal cover and store in a cool, dry place.
- The battery may be hot immediately after use or when the product has been used on battery power for an extended period. Before removing the battery turn the camera off and allow the battery to cool.
- Discontinue use immediately should you notice any changes in the battery, such as discoloration or deformation.
- Dust on or near the metal parts of the plug should be removed with a dry cloth. Continued use could result in fire.
- Do not go near the charger during thunderstorms. Failure to observe this precaution could result in electric shock.
- Do not handle the plug or charger with wet hands. Failure to observe this precaution could result in injury or product malfunction due to fire or electric shock.
- Do not use with travel converters or adapters designed to convert from one voltage to another or with DC-to-AC inverters. Failure to observe this precaution could damage the product or cause overheating or fire.

⚠ Use appropriate cables. When connecting cables to the input and output jacks, use only the cables provided or sold by Nikon for the purpose to maintain compliance with product regulations.

⚠ CD-ROMs: CD-ROMs containing software or manuals should not be played back on audio CD equipment. Playing CD-ROMs on an audio CD player could cause hearing loss or damage the equipment.

⚠ Observe proper precautions when handling the charger:

- Keep dry. Failure to observe this precaution could result in injury or product malfunction due to fire or electric shock.
- Do not short the charger terminals. Failure to observe this precaution could result in overheating and damage to the charger.

Notices

- No part of the manuals included with this product may be reproduced, transmitted, transcribed, stored in a retrieval system, or translated into any language in any form, by any means, without Nikon's prior written permission.
- Nikon reserves the right to change the specifications of the hardware and software described in these manuals at any time and without prior notice.
- Nikon will not be held liable for any damages resulting from the use of this product.
- While every effort has been made to ensure that the information in these manuals is accurate and complete, we would appreciate it were you to bring any errors or omissions to the attention of the Nikon representative in your area (address provided separately).

Notice for Customers in Canada

CAN ICES-3 B / NMB-3 B

Notice for Customers in Europe

CAUTION: RISK OF EXPLOSION IF BATTERY IS REPLACED BY AN INCORRECT TYPE. DISPOSE OF USED BATTERIES ACCORDING TO THE INSTRUCTIONS.

This symbol indicates that electrical and electronic equipment is to be collected separately.



The following apply only to users in European countries:

- This product is designated for separate collection at an appropriate collection point. Do not dispose of as household waste.
- Separate collection and recycling helps conserve natural resources and prevent negative consequences for human health and the environment that might result from incorrect disposal.
- For more information, contact the retailer or the local authorities in charge of waste management.

This symbol on the battery indicates that the battery is to be collected separately.



The following apply only to users in European countries:

- All batteries, whether marked with this symbol or not, are designated for separate collection at an appropriate collection point. Do not dispose of as household waste.
- For more information, contact the retailer or the local authorities in charge of waste management.

Notice for Customers in the U.S.A.

The Battery Charger

IMPORTANT SAFETY INSTRUCTIONS—SAVE THESE INSTRUCTIONS

DANGER—TO REDUCE THE RISK OF FIRE OR ELECTRIC SHOCK, CAREFULLY FOLLOW THESE INSTRUCTIONS

For connection to a supply not in the U.S.A., use an attachment plug adapter of the proper configuration for the power outlet if needed. This power unit is intended to be correctly oriented in a vertical or floor mount position.

Federal Communications Commission (FCC) Radio Frequency Interference Statement

This equipment has been tested and found to comply with the limits for a Class B digital device, pursuant to Part 15 of the FCC rules. These limits are designed to provide reasonable protection against harmful interference in a residential installation. This equipment generates, uses, and can radiate radio frequency energy and, if not installed and used in accordance with the instructions, may cause harmful interference to radio communications. However, there is no guarantee that interference will not occur in a particular installation. If this equipment does cause harmful interference to radio or television reception, which can be determined by turning the equipment off and on, the user is encouraged to try to correct the interference by one or more of the following measures:

- Reorient or relocate the receiving antenna.
- Increase the separation between the equipment and receiver.
- Connect the equipment into an outlet on a circuit different from that to which the receiver is connected.
- Consult the dealer or an experienced radio/television technician for help.



Nikon
1 V3

CAUTIONS

Modifications

The FCC requires the user be notified that any changes or modifications made to this device that are not expressly approved by Nikon Corporation may void the user's authority to operate the equipment.

Interface Cables

Use the interface cables sold or provided by Nikon for your equipment. Using other interface cables may exceed the limits of Class B Part 15 of the FCC rules.

Notice for Customers in the State of California

WARNING: Handling the cord on this product may expose you to lead, a chemical known to the State of California to cause birth defects or other reproductive harm. *Wash hands after handling.*

Nikon Inc., 1300 Walt Whitman Road, Melville, New York 11747-3064, U.S.A. Tel.: 631-547-4200

Notice Concerning Prohibition of Copying or Reproduction

Note that simply being in possession of material that has been digitally copied or reproduced by means of a scanner, digital camera, or other device may be punishable by law.

- **Items prohibited by law from being copied or reproduced**
- **Cautions on certain copies and reproductions**

Do not copy or reproduce paper money, coins, securities, government bonds, or local government bonds, even if such copies or reproductions are stamped "Sample."

The copying or reproduction of paper money, coins, or securities which are circulated in a foreign country is prohibited.

Unless the prior permission of the government has been obtained, the copying or reproduction of unused postage stamps or post cards issued by the government is prohibited.

The copying or reproduction of stamps issued by the government and of certified documents stipulated by law is prohibited.

The government has issued cautions on copies or reproductions of securities issued by private companies (shares, bills, checks, gift certificates, etc.), commuter passes, or coupon tickets, except when a minimum of necessary copies are to be provided for business use by a company. Also, do not copy or reproduce passports issued by the government, licenses issued by public agencies and private groups, ID cards, and tickets, such as passes and meal coupons.

- **Comply with copyright notices**

The copying or reproduction of copyrighted creative works such as books, music, paintings, woodcuts, prints, maps, drawings, movies, and photographs is governed by national and international copyright laws. Do not use this product for the purpose of making illegal copies or to infringe copyright laws.

AVC Patent Portfolio License

THIS PRODUCT IS LICENSED UNDER THE AVC PATENT PORTFOLIO LICENSE FOR THE PERSONAL AND NON-COMMERCIAL USE OF A CONSUMER TO (I) ENCODE VIDEO IN COMPLIANCE WITH THE AVC STANDARD ("AVC VIDEO") AND/OR (II) DECODE AVC VIDEO THAT WAS ENCODED BY A CONSUMER ENGAGED IN A PERSONAL AND NON-COMMERCIAL ACTIVITY AND/OR WAS OBTAINED FROM A VIDEO PROVIDER LICENSED TO PROVIDE AVC VIDEO. NO LICENSE IS GRANTED OR SHALL BE IMPLIED FOR ANY OTHER USE. ADDITIONAL INFORMATION MAY BE OBTAINED FROM MPEG LA, L.L.C. SEE <http://www.mpegla.com>

Disposing of Data Storage Devices

Please note that deleting images or formatting memory cards or other data storage devices does not completely erase the original image data. Deleted files can sometimes be recovered from discarded storage devices using commercially available software, potentially resulting in the malicious use of personal image data. Ensuring the privacy of such data is the user's responsibility.

Before discarding a data storage device or transferring ownership to another person, erase all data using commercial deletion software, or format the device and then completely refill it with images containing no private information (for example, pictures of empty sky). Wi-Fi settings can be reset to default values by selecting **Wi-Fi > Wi-Fi connection type > Reset Wi-Fi settings** in the setup menu (☐ 93). Care should be taken to avoid injury when physically destroying data storage devices.

Temperature Warnings

The camera may become warm to the touch during use; this is normal and does not indicate a malfunction. At high ambient temperatures, after extended periods of continuous use, or after several photographs have been taken in quick succession, a temperature warning may be displayed, following which the camera will turn off automatically to minimize damage to its internal circuits. Wait for the camera to cool before resuming use.

Use Only Nikon Brand Electronic Accessories

Nikon cameras are designed to the highest standards and include complex electronic circuitry. Only Nikon brand electronic accessories (including chargers, batteries, AC adapters, and lens accessories) certified by Nikon specifically for use with this Nikon digital camera are engineered and proven to operate within the operational and safety requirements of this electronic circuitry.

The use of non-Nikon electronic accessories could damage the camera and may void your Nikon warranty. The use of third-party rechargeable Li-ion batteries not bearing the Nikon holographic seal shown at right could interfere with normal operation of the camera or result in the batteries overheating, igniting, rupturing, or leaking.



For more information about Nikon brand accessories, contact a local authorized Nikon dealer.

Use Only Nikon Brand Accessories

Only Nikon brand accessories certified by Nikon specifically for use with your Nikon digital camera are engineered and proven to operate within its operational and safety requirements. THE USE OF NON-NIKON ACCESSORIES COULD DAMAGE YOUR CAMERA AND MAY VOID YOUR NIKON WARRANTY.

Servicing the Camera and Accessories

The camera is a precision device and requires regular servicing. Nikon recommends that the camera be inspected by the original retailer or a Nikon-authorized service representative once every one to two years, and that it be serviced once every three to five years (note that fees apply to these services). Frequent inspection and servicing are particularly recommended if the camera is used professionally. Any accessories regularly used with the camera, such as lenses, should be included when the camera is inspected or serviced.

Before Taking Important Pictures

Before taking pictures on important occasions (such as at weddings or before taking the camera on a trip), take a test shot to ensure that the camera is functioning normally. Nikon will not be held liable for damages or lost profits that may result from product malfunction.

Life-Long Learning

As part of Nikon's "Life-Long Learning" commitment to ongoing product support and education, continually-updated information is available on-line at the following sites:

- **For users in the U.S.A.:** <http://www.nikonusa.com/>
- **For users in Europe and Africa:** <http://www.europe-nikon.com/support/>
- **For users in Asia, Oceania, and the Middle East:** <http://www.nikon-asia.com/>

Visit these sites to keep up-to-date with the latest product information, tips, answers to frequently-asked questions (FAQs), and general advice on digital imaging and photography. Additional information may be available from the Nikon representative in your area. For contact information, visit <http://imaging.nikon.com/>

Wireless

This product, which contains encryption software developed in the United States, is controlled by the United States Export Administration Regulations and may not be exported or re-exported to any country to which the United States embargoes goods. The following countries are currently subject to embargo: Cuba, Iran, North Korea, Sudan, and Syria.

Notices for Customers in the U. S. A.

This device complies with Part 15 of the FCC Rules. Operation is subject to the following two conditions: (1) this device may not cause harmful interference, and (2) this device must accept any interference received, including interference that may cause undesired operation.

FCC WARNING

The FCC requires the user to be notified that any changes or modifications made to this device that are not expressly approved by Nikon Corporation may void the user's authority to operate the equipment.

FCC Radio Frequency Interference Statement

Note: This equipment has been tested and found to comply with the limits for a Class B digital device, pursuant to part 15 of the FCC Rules. These limits are designed to provide reasonable protection against harmful interference in a residential installation. This equipment generates, uses and can radiate radio frequency energy and, if not installed and used in accordance with the instructions, may cause harmful interference to radio communications. However, there is no guarantee that interference will not occur in a particular installation. If this equipment does cause harmful interference to radio or television reception, which can be determined by turning the equipment off and on, the user is encouraged to try to correct the interference by one or more of the following measures:

- Reorient or relocate the receiving antenna.
- Increase the separation between the equipment and receiver.
- Connect the equipment into an outlet on a circuit different from that to which the receiver is connected.
- Consult the dealer or an experienced radio/TV technician for help.

Co-location

This transmitter must not be co-located or operated in conjunction with any other antenna or transmitter.

Nikon Inc., 1300 Walt Whitman Road, Melville, New York 11747-3064, U.S.A.
Tel.: 631-547-4200

Notices for Customers in Canada

CAN ICES-3 B / NMB-3 B

This device complies with Industry Canada licence-exempt RSS standard(s). Operation is subject to the following two conditions: (1) this device may not cause interference, and (2) this device must accept any interference, including interference that may cause undesired operation of the device.

FCC/IC RF Exposure Statement

The available scientific evidence does not show that any health problems are associated with using low power wireless devices. There is no proof, however, that these low power wireless devices are absolutely safe. Low power Wireless devices emit low levels of radio frequency energy (RF) in the microwave range while being used. Whereas high levels of RF can produce health effects (by heating tissue), exposure of low-level RF that does not produce heating effects causes no known adverse health effects. Many studies of low-level RF exposures have not found any biological effects. Some studies have suggested that some biological effects might occur, but such findings have not been confirmed by additional research. The 1 V3, which is equipped with a LBWA1ZZYM6 (FCC ID:VPYLBYM / IC ID:772C-LBYM) wireless LAN module, has been tested and found to comply with FCC/IC radiation exposure limits set forth for an uncontrolled environment and meets the FCC radio frequency (RF) Exposure Guidelines in Supplement C to OET65 and RSS-102 of the IC radio frequency (RF) Exposure rules. Please refer to the SAR test report that was uploaded to FCC website.

Notices for Customers in Europe

Hereby, Nikon Corporation, declares that the 1 V3 is in compliance with the essential requirements and other relevant provisions of Directive 1999/5/EC. The declaration of conformity may be consulted at http://imaging.nikon.com/support/pdf/DoC_1V3.pdf



Notice for Customers in Singapore

Trade Name: Nikon Model: 1 V3

This device complies with radio-frequency regulations. The content of certification labels not affixed to the device is given below.

Complies with IDA Standards DA104328
--

Security

Although one of the benefits of this product is that it allows others to freely connect for the wireless exchange of data anywhere within its range, the following may occur if security is not enabled:

- Data theft: Malicious third-parties may intercept wireless transmissions to steal user IDs, passwords, and other personal information.
- Unauthorized access: Unauthorized users may gain access to the network and alter data or perform other malicious actions. Note that due the design of wireless networks, specialized attacks may allow unauthorized access even when security is enabled.

Introduction

The Camera and Accessories

The following items are included with purchase of this product or are available separately. Confirm that the package contains all items listed as included. For a complete list of the accessories available for separate purchase, see page 109.



Body Cap BF-N1000 (included)

Digital Camera Nikon 1 V3 (included)

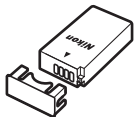

Rechargeable Li-ion Battery EN-EL20a (included with terminal cover)



Lens (supplied only if lens kit is purchased with camera)



Battery Charger MH-29 (included; plug adapter supplied in countries or regions where required; shape depends on country of sale)

Also included:

- Strap AN-N1000
- USB Cable UC-E20
- ViewNX 2 CD
- Warranty
- User's Manual (this manual)



Electronic Viewfinder DF-N1000* (available separately)

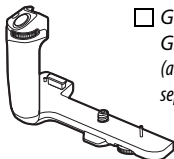

Grip GR-N1010 (available separately)

*Nikon 1 V1 and V2 not supported.

Memory cards are sold separately.



Parts of the Camera

Take a few moments to familiarize yourself with camera controls and displays. You may find it helpful to bookmark this section and refer to it as you read through the rest of the manual.

The Camera Body

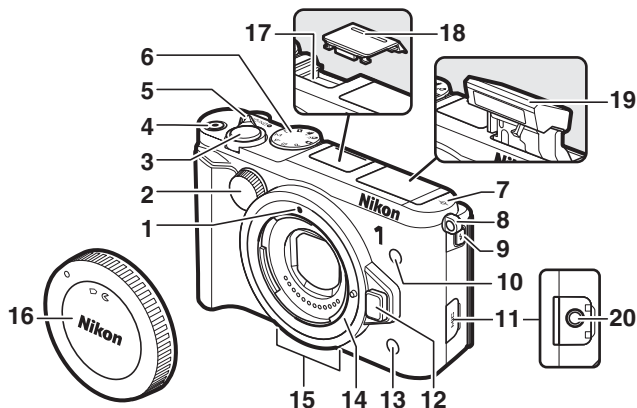

1 Mounting mark	22	11 External microphone connector cover	
2 Sub-command dial	58, 59	12 Lens release button	
3 Shutter-release button	33, 52, 63, 66, 68, 72	13 Infrared receiver	79, 119
4 Movie-record button	48, 49	14 Lens mount	22
5 Power switch	24	15 Microphone	101
6 Mode dial	7	16 Body cap	110
7 Focal plane mark (∞)		17 Multi accessory port	
8 Eyelet for camera strap	20	18 Multi accessory port cover	
9 Flash pop-up button	81	19 Built-in flash	81
10 AF-assist illuminator	100	20 Connector for external microphone	110
Self-timer lamp	78		
Red-eye reduction lamp	82		

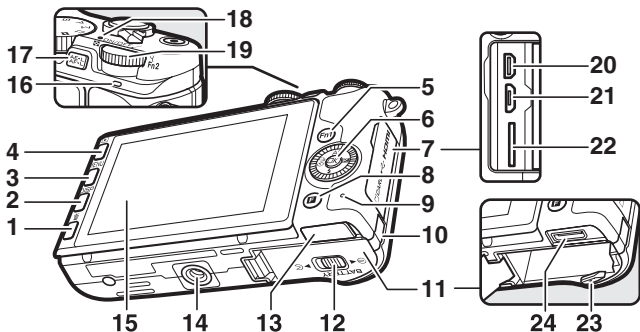

1 (delete) button.....36	11 Battery-chamber cover 21
2 DISP (display) button 5	12 Battery-chamber cover latch.....21
3 MENU (menu) button 8	13 Grip connector cover29
4 (playback) button35, 69, 74	14 Tripod socket *.....
5 Fn1 button 12	15 Vari-angle monitor 4, 13, 24
6 Multi selector..... 9	16 Speaker
OK (OK) button..... 9	17 (AE/AF lock) button
AF (focus mode) 100	18 Power lamp 24
(exposure compensation)	19 Main command dial/ Fn2 button 12, 35, 57, 59
(flash mode).....81	20 HDMI connector
(continuous shooting/ self-timer).....75, 77, 79	21 USB connector..... 106
7 Memory card slot/connector cover21	22 Memory card slot.....21
8 (feature) button 10	23 Battery latch.....21
9 Memory card access lamp34	24 Grip connector 29
10 Power connector cover for optional power connector	

* Camera does not support TA-N100 tripod mounting spacer.



The Monitor

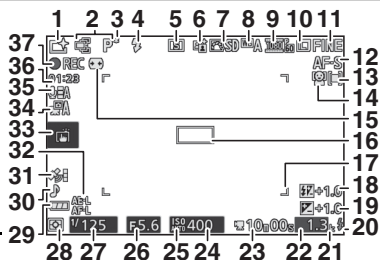
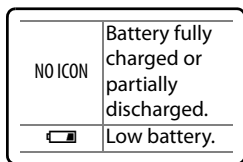

1 Shooting mode 7	20 Flash-ready indicator 83
2 Live image control 37	21 "k" (appears when memory remains for over 1000 exposures) 26
Creative mode 39	22 Number of exposures remaining 26
Best moment capture selection 61, 65, 67	Number of shots remaining before memory buffer fills
Advanced movie selection 48, 51	White balance recording indicator
Exposure mode 99	Card warning indicator
3 Flexible program indicator 56	23 Time available 49
4 Flash mode 82	24 ISO sensitivity 101
5 Self-timer 77	25 ISO sensitivity indicator 101
Remote control mode 79	Auto ISO sensitivity indicator
Continuous mode * 75	26 Aperture 58, 59
6 Active D-Lighting * 100	27 Shutter speed 57, 59
7 Picture Control * 101	28 Metering 100
8 White balance * 101	29 Battery indicator * 102
9 Frame size/frame rate 101	30 Sound settings * 102
10 Image size * 99	31 Satellite signal indicator * 100
11 Image quality * 99	32 Autoexposure (AE)/autofocus (AF) lock indicator
12 Focus mode * 100	33 Tap shooting options 85
13 AF-area mode * 100	34 Auto image capture 101
14 Face-priority * 34, 100	35 Microphone sensitivity * 49
15 Auto distortion control indicator 100	36 Time elapsed 49
16 Focus area 33, 100	37 Recording indicator 49
17 AF-area brackets * 100	
18 Flash compensation 100	
19 Exposure compensation	

* Available only in detailed display; to view, press DISP (□ 5).

Note: Display shown with all indicators lit for illustrative purposes.

The DISP (Display) Button

Press DISP to cycle through shooting and playback indicators as shown below.

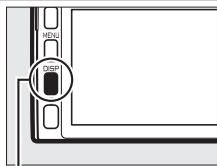

DISP button

Shooting

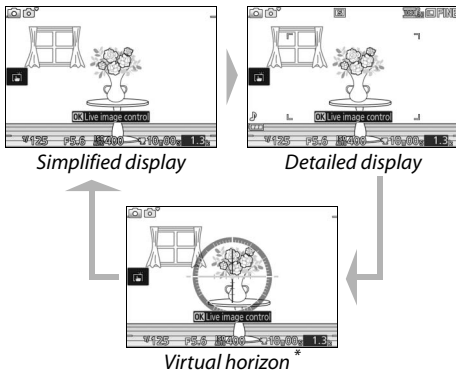

* Displayed only in modes other than **Creative Palette**.

Recording Area

The area recorded during movie recording is shown by guides in the display; the appearance of the guides depends on the option selected for **Electronic VR** (100, 101) in movie menu.

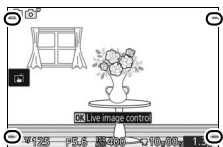

Electronic vibration reduction off

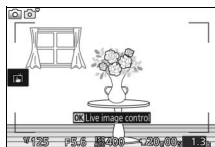

Electronic vibration reduction on

■ Playback

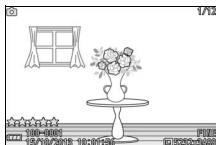

Simple photo info

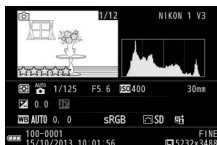

Detailed photo info

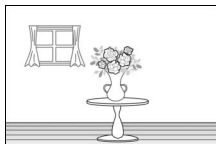
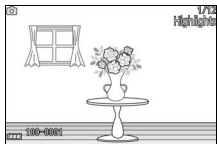

Image only



*Highlights**

*Displayed only when **On** is selected for the **Display > Playback highlight display** option in the setup menu (☐ 102).

The Mode Dial

The camera offers a choice of the following shooting modes:

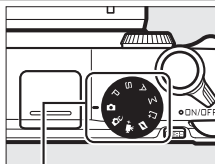



Mode dial

 **Auto mode** (□ 31): Let the camera pick the settings for photographs and movies.

 **Creative mode** (□ 39): For photographs in which you want to use special effects or match settings to the scene.

 **Advanced movie mode** (□ 48): Choose an exposure mode and adjust shutter-speed or aperture or record movies in slow or fast motion or with other special effects.

 **Motion Snapshot mode** (□ 71): Each time the shutter is released, the camera records a still image and about 1.6 s of movie footage.

 **Best moment capture mode** (□ 61): Choose **Active Selection** to select the best picture from 40 shots in temporary storage, **Slow view** to choose the best timing for the shot while the scene plays back in slow motion, or **Smart Photo Selector** to let the camera pick the best shot based on composition and movement.

P, S, A, and M modes (□ 56): Control shutter speed and aperture for advanced photographic effects.

- **P**: Programmed auto (□ 56)
- **A**: Aperture-priority auto (□ 58)
- **S**: Shutter-priority auto (□ 57)
- **M**: Manual (□ 59)



The MENU Button



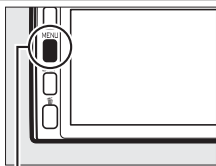





Most shooting, playback, and setup options can be accessed from the camera menus. To view the menus, press the MENU button.



MENU button

Tabs

Choose from the following menus:

-  Playback menu (p. 98)
-   P S A M  Shooting menu (p. 99)
-  Movie menu (p. 100)
-  Image processing menu (p. 101)
-  Setup menu (p. 102)
-  Wi-Fi menu (p. 88)

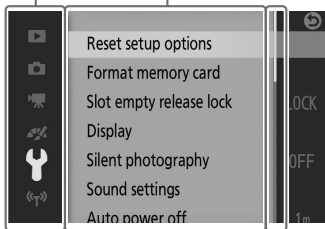

Menu options
Options in current menu.

Slider shows position in current menu.

Using the Menus

The items listed may vary with camera settings. Items displayed in gray are not currently available. To exit the menus and return to shooting mode, press the shutter-release button halfway.

■ Using the Menus

Use the multi selector to navigate the playback, shooting, movie, image processing, setup, and Wi-Fi menus.

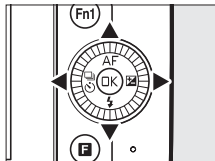

Multi selector

1 Select a menu.

Press ▲ or ▼ to highlight tabs and press ► to position the cursor in the highlighted menu.

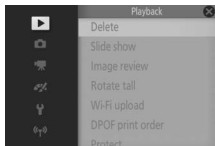

2 Select an item.

Press ▲ or ▼ to highlight menu items and press ► to view options for the highlighted item.

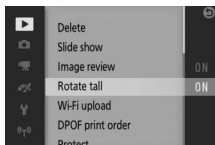

3 Select an option.

Press ▲ or ▼ to highlight the desired option and press **OK** to select.

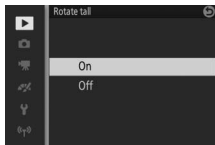

✎ Using the Multi Selector

Press the multi selector up, down, left, or right (▲, ▼, ◀, or ▶), or rotate it as shown at right.



The **F** (Feature) Button

To display the feature menu and adjust camera settings or access playback options, press the **F** button.

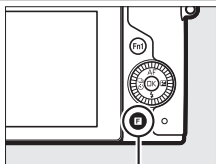

F button

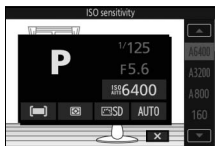

F menu (shooting mode)

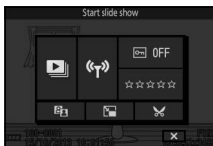

F menu (playback)

1 Select an item.

Use the multi selector to highlight an item and press **OK** to display options (to exit the **F** menu, press the shutter-release button halfway as described on page 33 or highlight **X** and press **OK**).

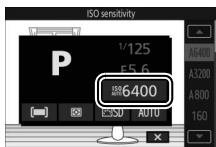

2 Select an option.

Highlight the desired option or value and press **OK** to select.

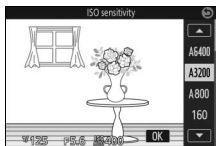

The **F** Menu

The **F** menu is context-sensitive: its contents vary with camera settings or the type of image displayed; options that are currently unavailable are shown in gray. The **F** menu is not available in auto mode.



The Function Buttons (Fn1 and Fn2)

The **Fn1** and **Fn2** buttons can be used for quick recall of frequently-used settings during shooting. To choose the roles these buttons play, go to **Assign Fn button** in the setup menu (☞ 102), highlight the desired button, press **▶**, and choose from the following options:



Fn2 button

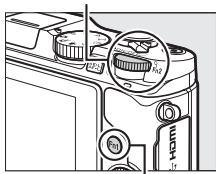

Fn1 button

- Exposure compensation
- Metering (☞ 100)
- White balance (☞ 101)
- ISO sensitivity (☞ 101)
- Picture Control (☞ 101)
- AF-area mode (☞ 100)
- Movie-record button

If **Movie-record button** is selected, the chosen button can be used to start and end movie recording (☞ 49).

Users of the optional grip (☞ 29) can also choose the role played by the **Fn3** button.

Fn3 button

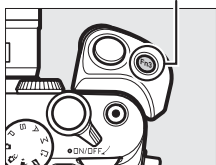

Default Settings

At default settings, the **Fn1**, **Fn2**, and **Fn3** buttons are respectively assigned white balance, ISO sensitivity, and movie recording functions.

The Fn2 Button

The main command dial doubles as the **Fn2** button. To access the function assigned to the **Fn2** button, press the command dial.

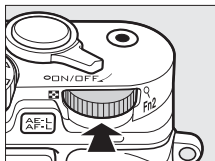

Fn2 button

Using the Vari-Angle Monitor

The monitor can be angled and rotated as shown below.

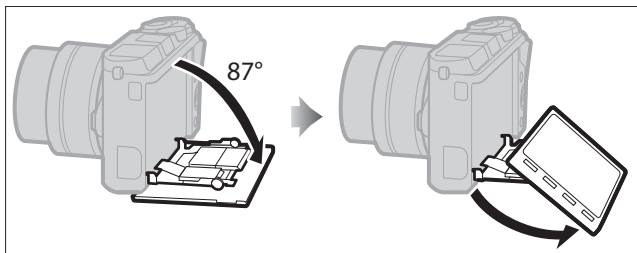

Normal use: The monitor is normally used in storage position.

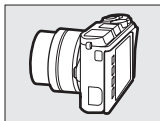

Low-angle shots: Frame shots with the camera close to the ground. Once in the low-angle position, the monitor can be further lowered.

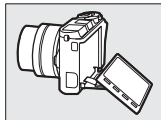
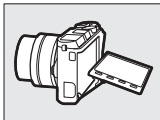
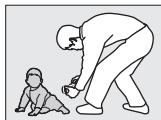
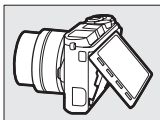

High-angle shots: Frame shots while holding the camera over your head.

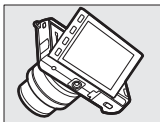

✔ Using the Monitor

Rotate the monitor gently within the limits shown on page 13. *Do not use force.* Failure to observe these precautions could damage the camera or monitor. If the camera is mounted on a tripod, care should be taken to ensure that the monitor does not contact the tripod.

Do not touch the area to the rear of the monitor. Failure to observe this precaution could cause product malfunction.

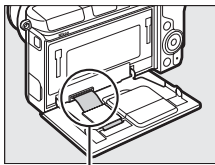

Be particularly careful not to touch this area.



Using the Touch Screen

The touch-sensitive monitor supports the following operations:

Tap

Tap the monitor.



Flick

Flick a finger a short distance across the monitor.

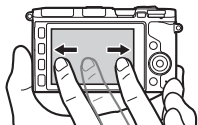

Slide

Slide a finger over the monitor.

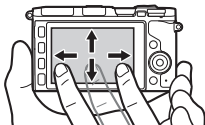

Stretch/Pinch

Place two fingers on the monitor and move them apart or pinch them together.

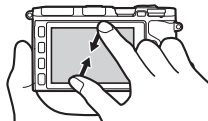

The Touch Screen

The touch screen responds to static electricity and may not respond when covered with third-party protective films or when touched with fingernails or gloved hands. Do not use excessive force or touch the screen with sharp objects.

Using the Touch Screen

The camera may not recognize a tap if you leave your finger on the screen too long. It may not recognize other gestures if your touch is too soft, your fingers are moved too quickly or too short a distance or do not remain in contact with the screen, or if the movement of the two fingers in a pinch or stretch is not correctly coordinated.



■ Taking Pictures

The touch screen can be used for the following shooting operations.

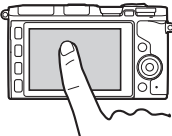
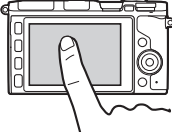
Take a picture (tap shooting)		In auto, creative, P, S, A, and M modes, you can focus and take a picture by tapping your subject in the display.
Focus (tap shooting)		In advanced movie mode, you can focus by tapping your subject in the display.

Adjust settings

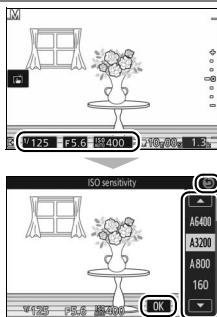

Tap highlighted icons to view settings and tap icons or sliders to change (the items available will vary with camera settings). Tap **OK** to save changes and exit, or tap **↶** to return to the previous display.

Tap Shooting Options

Tap shooting options can be adjusted by tapping the icon shown at right (85).

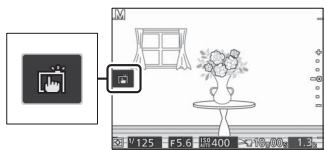

Viewing Pictures

The touch screen can be used for the following playback operations.

View other images

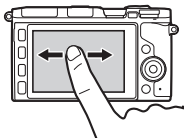

Flick left or right to view other images.





View movies or panoramas

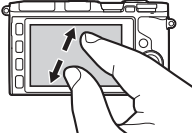

Guide

Tap the on-screen guide to start movie or panorama playback (movies are indicated by a  icon). Tap the display to pause or resume.

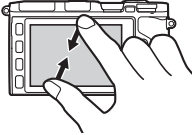
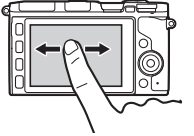

Zoom in		<p>Use stretch and pinch gestures to zoom in and out and slide to scroll. You can also double-tap a picture in full-frame playback to zoom in and double-tap again to exit zoom.</p>
 View thumbnails		<p>To “zoom out” to a thumbnail view, use a pinch gesture in full-frame playback. Use pinch and stretch to choose the number of images displayed from 4, 9, or 16 frames.</p>
View other months		<p>Flick left or right to view other months in the calendar display.</p>
Use on-screen guides		<p>Various operations can be performed by tapping on-screen guides.</p>

■ ■ Using the Menus

The touch screen can be used for the following menu operations.

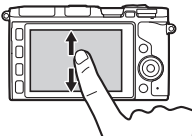
Scroll		<p>Slide up or down to scroll.</p>
---------------	---	------------------------------------

Choose a menu



Tap a menu icon to choose a menu.

Adjust settings

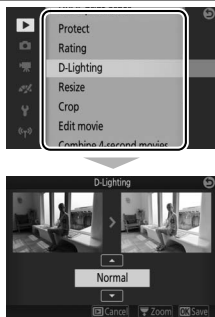

Tap menu items to display options and tap icons or sliders to change. Tap  to return to the previous display.





■ The **F** Menu

The touch screen can be used to adjust settings in the **F** menu.

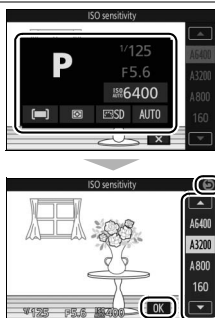
Adjust settings



Tap menu items to display options and tap icons or sliders to change. Tap  to save changes and exit, or tap  to return to the previous display.

First Steps

1 Attach the camera strap.

Attach the strap securely to the two camera eyelets.

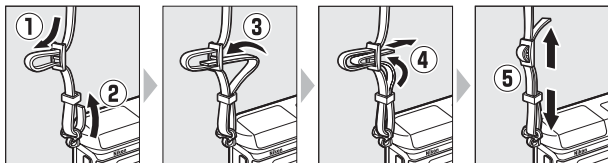

2 Charge the battery.

Insert the battery into the charger ① and plug the charger in ②. An exhausted battery fully charges in about 3 hours. Unplug the charger and remove the battery when charging is complete.

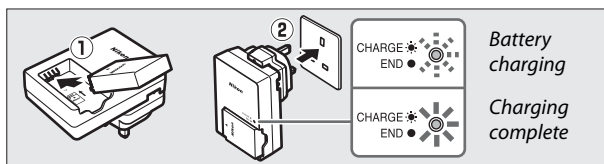

The Plug Adapter

Depending on the country or region of purchase, a plug adapter may be supplied with the charger. The shape of the adapter varies with the country or region of purchase. If a plug adapter is supplied, raise the wall plug and connect the plug adapter as shown at right, making sure the plug is fully inserted. Attempting to forcibly remove the plug adapter could damage the product.

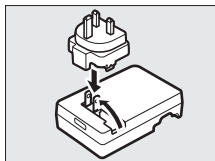

3 Insert the battery.

Insert the battery in the orientation shown, using the battery to keep the orange battery latch pressed to one side. The latch locks the battery in place when the battery is fully inserted.

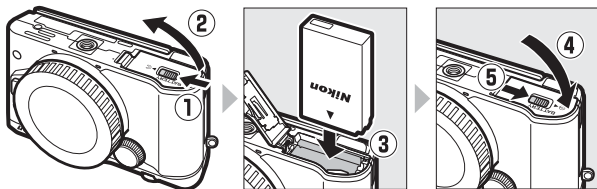

4 Insert a memory card.

The camera stores pictures on microSD, microSDHC, and microSDXC memory cards (available separately;  111). Check to be sure the card is in the correct orientation and then slide the card until it clicks into place. Do not attempt to insert the card at an angle; failure to observe this precaution could damage the product.

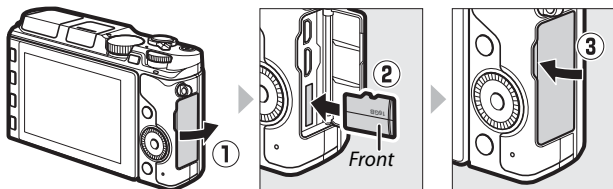

Formatting Memory Cards

If this is the first time the memory card will be used in the camera or if the card has been formatted in another device, select **Format memory card** in the setup menu and follow the on-screen instructions to format the card ( 102). *Note that this permanently deletes any data the card may contain.*



5 Attach a lens.

Be careful to prevent dust from entering the camera when the lens or body cap is removed. The lens generally used in this manual for illustrative purposes is a 1 NIKKOR VR 10–30mm f/3.5–5.6 PD-ZOOM. When using the 1 NIKKOR VR 10–30mm f/3.5–5.6 PD-ZOOM, be sure not to touch the lens cover; failure to observe this precaution could result in product malfunction.

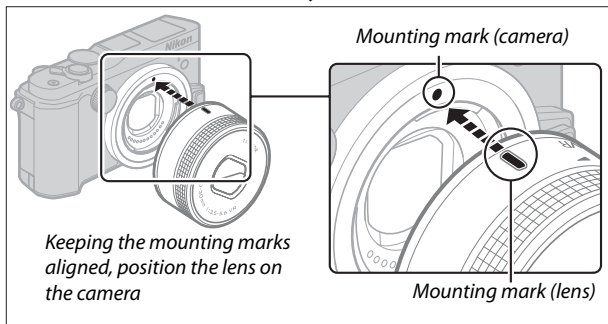
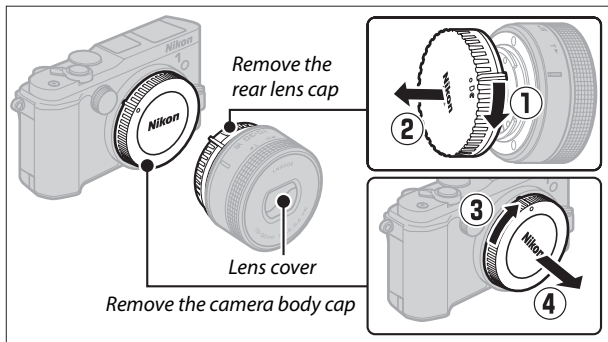

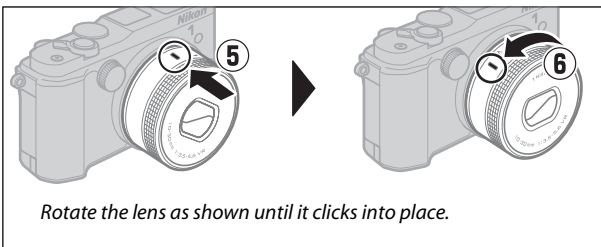

Lenses with Retractable Lens Barrel Buttons

Lenses with retractable lens barrel buttons can not be used when retracted. To unlock and extend the lens, readying the camera for use, keep the retractable lens barrel button pressed (1) while rotating the zoom ring as shown (2). The lens can be retracted and the zoom ring locked by pressing the button and rotating the ring in the opposite direction. Retract the lens before removal, and be careful not to press the retractable lens barrel button while attaching or removing the lens.

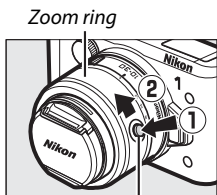

Retractable lens barrel button

The camera will turn on automatically when the retractable lens barrel lock is released; in addition, if the view through the lens is displayed or the monitor is off, the camera will turn off when the lens barrel is locked (in the case of 1 NIKKOR VR 10–30mm f/3.5–5.6 and 1 NIKKOR VR 30–110mm f/3.8–5.6 lenses, firmware version 1.10 or later is required if locking the lens barrel is to turn the camera off when the monitor is off; for information on updating lens firmware, visit the Nikon website for your area).

6 Turn the camera on.

Rotate the power switch to turn the camera on. The power lamp will briefly light green and the monitor will turn on. If the lens is equipped with a front lens cap, remove the cap before shooting. If a 1 NIKKOR VR 10–30mm f/3.5–5.6 PD-ZOOM lens is attached, the lens will automatically extend when the camera is turned on and retract when the camera is turned off.

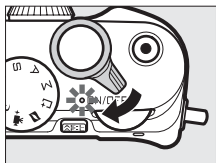



Turning the Camera Off

To turn the camera off, rotate the power switch again. The monitor will turn off.

Auto Power Off

If no operations are performed for about a minute, the displays will turn off and the power lamp start to flash. The camera can be reactivated by operating the shutter-release button. If no operations are performed for about three minutes after the displays have turned off, the camera will turn off automatically.

7 Choose a language.

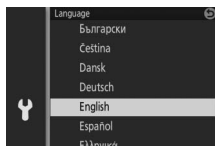

A language-selection dialog will be displayed the first time the camera is turned on. Use the multi selector and  button ( 9) to choose a language.





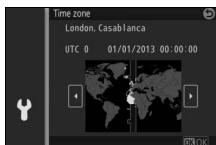
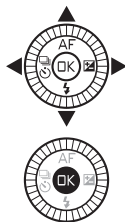

8 Set the clock.

Use the multi selector and  button (book 9) to set the time and date. *Note that the camera uses a 24-hour clock.*

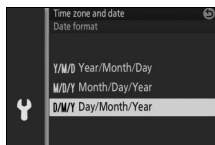



Press  or  to highlight time zone and press .



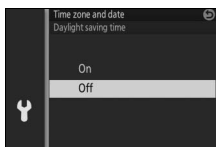



Press  or  to highlight date format and press .

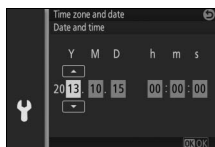

Press  or  to highlight daylight saving time option and press .



Press  or  to highlight items and press  or  to change. Press  to exit to shooting display when setup is complete.

Note: Language and clock can be changed at any time using **Language** (book 102) and **Time zone and date** (book 102) options in setup menu.



9 Check the battery level and memory card capacity.

Check the battery level and number of exposures remaining in the monitor (📖 4).

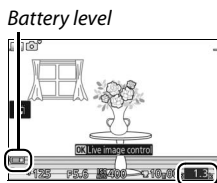

Attaching a Grip and Electronic Viewfinder

If desired, the camera can be used with an optional grip and electronic viewfinder (📖 109). Manuals are not provided; users of these accessories will need to read following instructions in their entirety before proceeding.

Attaching an Electronic Viewfinder

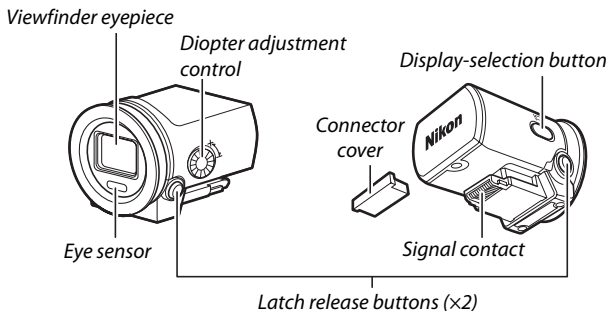

Follow the steps below to attach the viewfinder.

1 Remove the multi-accessory port cover.

Remove the cover from the camera as shown. Be sure to replace the cover when the port is not in use.

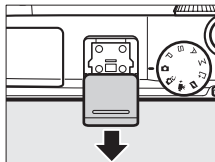

2 Remove the connector cover.

Remove the connector cover from the electronic viewfinder. Be sure to replace the cover when the viewfinder is not in use.

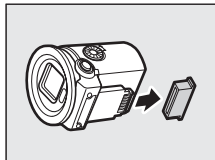

3 Attach the viewfinder.

After confirming that the camera is off, slide the signal contact into the multi-accessory port until it latches.

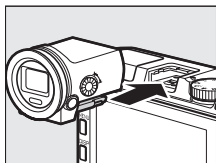

Handling the Viewfinder

Remove the viewfinder when it is not in use. If the viewfinder is attached, the shocks and vibration to which the camera may be exposed during transport or when placed in a bag could damage the camera or viewfinder. To remove the viewfinder, confirm that the camera is off and then press and hold the latch release buttons while detaching the viewfinder from the multi accessory port.

Do not touch the viewfinder signal contact. Failure to observe this precaution could cause product malfunction.

Using the Viewfinder

Use the viewfinder when bright ambient lighting conditions make it difficult to see the display in the monitor. When you put your eye to the viewfinder, the eye sensor will turn the viewfinder on and the monitor off (note that the sensor responds to more than just your eyes; when using the monitor, keep your fingers and other objects from the sensor). You can also use the display-selection button to cycle through display settings as follows: automatic display selection (**Eye sensor on**); viewfinder on, monitor off (**Eye sensor off**); and monitor on, viewfinder off. The eye sensor is re-enabled automatically each time the camera is turned on. While the viewfinder is on, you can use the DISP button to view or hide indicators (□ 5).

Viewfinder Focus

If you find that the icons and other indicators displayed in the viewfinder seem blurry, rotate the diopter adjustment control until the display is in sharp focus. When operating the control with your eye to the viewfinder, be careful not to put your fingers or fingernails in your eyes.

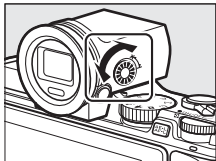

Attaching a Grip

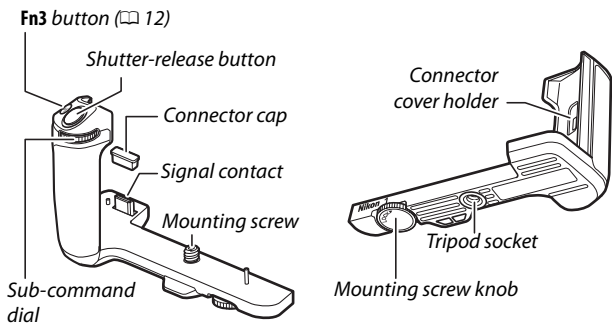

Follow the steps below to attach the grip.

1 Remove the grip connector cover.

Remove the grip connector cover from the bottom of the camera and place it in the holder. Be sure to replace the cover when the grip is not in use.

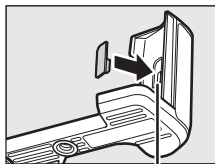
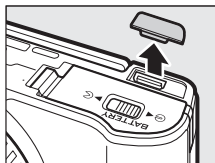

Connector cover holder

2 Remove the connector cap.

Remove the grip connector cap. Be sure to replace the cap when the grip is not in use.

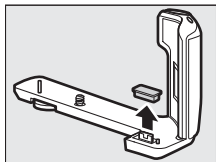

3 Attach the grip.

After confirming that the camera is off, align the camera and grip as shown and tighten the knob by rotating it in the **LOCK** direction, keeping the grip held in place so that the grip signal contact slides straight into the camera grip connector.

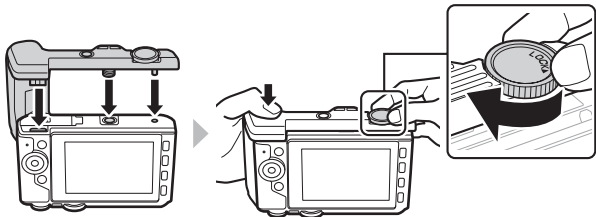

Removing the Grip

To remove the grip, confirm that the camera is off and then loosen the mounting screw by rotating the knob in the direction opposite to that shown by the **LOCK** indicator.

Handling the Grip

Do not touch the signal contacts. Failure to observe this precaution could cause product malfunction.

Taking and Viewing Photographs

This chapter describes how to take, view, and delete photographs in auto and creative mode.

Point-and-Shoot Photography (Auto Mode)

Follow the steps below to take photographs in auto mode, a “point-and-shoot” mode in which the camera automatically detects the subject type and adjusts settings according to the subject and situation.

1 Turn the camera on.

Rotate the power switch to turn the camera on.

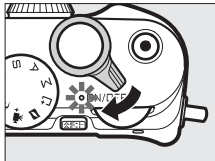

2 Select mode.

Rotate the mode dial to  (auto).

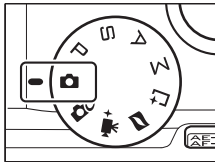

The Framing Grid

A framing grid can be displayed by selecting **On** for **Display > Grid display** in the setup menu ([102](#)).

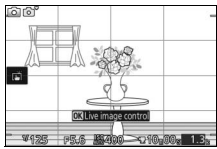

3 Ready the camera.

Hold the camera securely with both hands, being careful not to obstruct the lens, AF-assist illuminator, or microphone. Rotate the camera as shown at lower right when taking pictures in “tall” (portrait) orientation.

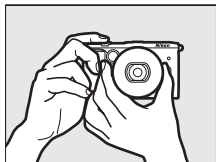

Shutter speeds slow when lighting is poor; use of the built-in flash (81) or a tripod is recommended.

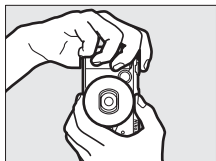

4 Frame the photograph.

Position your subject in the center of the frame.

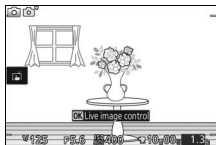

Using a Zoom Lens

Use the zoom ring to zoom in on the subject so that it fills a larger area of the frame, or zoom out to increase the area visible in the final photograph. During movie recording with the 1 NIKKOR VR 10–30mm f/3.5–5.6 PD-ZOOM, the zoom rate is unaffected by the speed with which the ring is rotated.

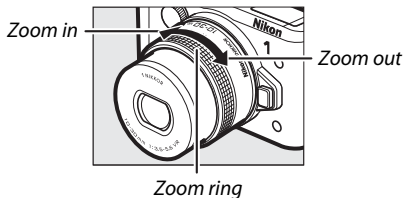

5 Focus.

Press the shutter-release button halfway to focus. If the subject is poorly lit, the AF-assist illuminator ( 2) may light to assist the focus operation.

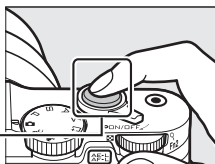

If the camera is able to focus, the selected focus area will be highlighted in green and a beep will sound (a beep may not sound if the subject is moving).

Focus area

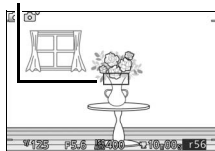





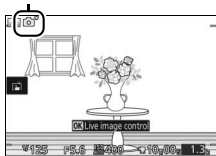

If the camera is unable to focus, the focus area will be displayed in red.

Automatic Scene Selection

In auto mode, the camera automatically analyzes the subject and selects the appropriate scene. The selected scene is shown in the monitor.

Scene icon



- | | |
|---|---|
|  | Portrait: Human portrait subjects. |
|  | Landscape: Landscapes and cityscapes. |
|  | Night portrait: Portrait subjects framed against dark backgrounds. |
|  | Close up: Subjects close to the camera. |
|  | Night landscape: Poorly-lit landscapes and cityscapes. |
|  | Auto: Subjects that do not fall into the categories listed above. |



6 Shoot.

Smoothly press the shutter-release button the rest of the way down to release the shutter and record the photograph. The memory card access lamp will light and the photograph will be displayed in the monitor for a few seconds (the photo will automatically clear from the display when the shutter-release button is pressed halfway). *Do not eject the memory card or remove the battery until the lamp has gone out and recording is complete.*

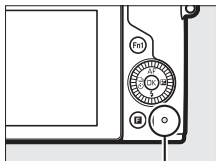
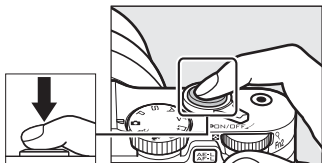

Memory card access lamp

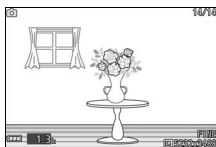

Face Priority

The camera detects and focuses on portrait subjects (face priority). A double yellow border will be displayed if a portrait subject is detected facing the camera (if multiple faces, up to a maximum of five, are detected, the camera will select the closest subject). Press the shutter-release button halfway to focus on the subject in the double yellow border. The border will clear from the display if the camera can no longer detect the subject (because, for example, the subject has looked away).



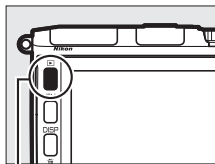

Viewing Photographs

Press  to display your most recent photograph full frame in the monitor (full-frame playback).

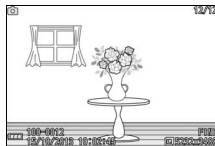

 button



Press  or  or rotate the multi selector to view additional pictures.



To zoom in on the center of the current image, rotate the main command dial to the right. Rotate left to zoom out. To view multiple images, rotate the dial left when the picture is displayed full frame.

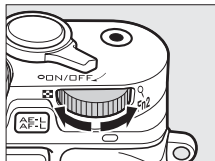

Main command dial

To end playback and return to shooting mode, press the shutter-release button halfway.

Deleting Pictures

To delete the current picture, press . *Note that once deleted, pictures can not be recovered.*

1 Display the photograph.

Display the photograph you wish to delete as described on the preceding page.

2 Press .

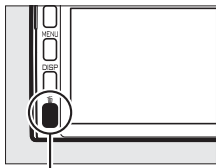

A confirmation dialog will be displayed.



 button



3 Delete the photograph.

Press  again to delete the picture and return to playback, or press  to exit without deleting the picture.

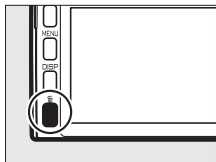

Deleting Multiple Pictures

The **Delete** option in the playback menu ( 98) can be used to delete selected pictures, all pictures, or pictures taken on selected dates.

Live Image Control

Live image controls let you preview how changes to each control will affect the final photograph. To choose a live image control for auto mode, press **OK** to display the live image control menu, then use the multi selector to highlight a control and press **OK** to view the effect. Rotate the multi selector to choose a setting and press **OK** to select.



Active D-Lighting: Preserve details in highlights and shadows for natural contrast.



Active D-Lighting: High *Active D-Lighting: Low*

Background softening: Soften background details to make your subject stand out, or bring both background and foreground into focus.



Background sharp

Background softened

Increase effect

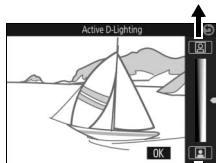

Reduce effect

Sharpen background

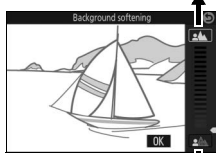

Soften background



Motion control: Suggest motion by blurring moving objects, or “freeze” motion to capture moving objects clearly.



Freeze motion

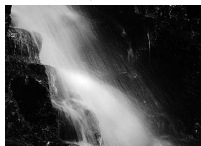

Blur motion

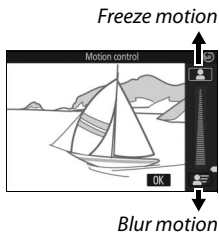

Brightness control: Make pictures brighter or darker.



Brighter



Darker

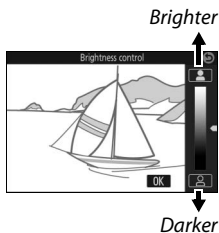

Live Image Control

Continuous shooting is not available (75) and the built-in flash and optional flash units can not be used when live image control is in effect. Pressing the movie-record button cancels live image control.

Choosing a Creative Mode

Choose creative mode to match settings to the subject or situation or take photos using special effects.

1 Select **CC** mode.

Rotate the mode dial to **CC** (creative).

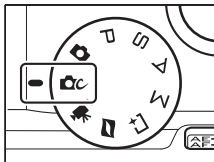

2 Choose an option.

Press **F** (feature) to display the **F** menu, then highlight **Creative** and press **OK**. Highlight an option suited to your subject and creative intent (see page 40) and press **OK**.

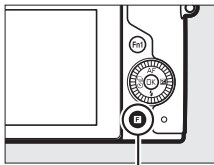

F button



Choosing a Mode That Matches the Subject or Situation

Choose a creative mode according to the subject or situation:

Option	Description
Creative Palette (🎨)	Rotate the palette to choose creative effects while previewing them in the display (□ 41).
HDR (HDR)	Photograph high-contrast scenes (□ 42).
Easy panorama (📷)	Shoot panoramas for later viewing on the camera (□ 43).
Soft (👤)	Shoot photographs with a soft filter effect. Use the F (feature) menu to select the amount of softening and to choose how softening applies to portraits.
Miniature effect (🏠)	The top and bottom of each photo is blurred so that the subject appears to have been a diorama photographed at short range. Works best when shooting from a high vantage point.
Selective color (🖌️)	Take photos in which only a selected hue appears in color (□ 46).
Cross process (🌀)	Choose a base color to create photographs with different hues (□ 47).
Toy camera effect (📷)	Shoot photographs with a toy camera effect. Use the F menu to adjust color saturation and peripheral illumination.



The Creative Palette

To choose a creative effect, rotate the multi selector or use a finger to rotate the creative palette in the monitor. The selected effect is visible in the monitor and changes gradually as the palette is rotated.

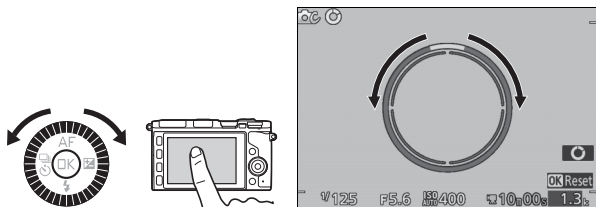

Press the shutter-release button all the way down to take a picture with the selected effect (tap shooting options are not available when the creative palette is displayed; to view or hide the creative palette, tap ). The built-in flash and optional flash units can not be used.

Scene Detection

The camera automatically adjusts settings to suit the subject and situation. The effects available vary with the type of subject detected. To reset the palette, press  or tap **Reset** while the creative palette is displayed.

HDR

Details in highlights and shadows are preserved using HDR (high dynamic range). Each time the shutter-release button is fully pressed, the camera takes two shots in quick succession and combines them to preserve details in highlights and shadows in high-contrast scenes; the built-in flash and optional flash units do not fire. Some time may be required to process the pictures; the final photograph will be displayed when processing is complete.



*First exposure
(darker)*

+



*Second exposure
(brighter)*



*Combined HDR
image*

Framing HDR Photographs

The edges of the image will be cropped out. The desired results may not be achieved if the camera or subject moves during shooting. Depending on the scene, shading may be uneven and shadows may appear around bright objects or halos around dark objects.

Easy Panorama

Follow the steps below to shoot panoramas. During shooting, the camera focuses using auto-area AF; face detection (📖 34) is not available. Exposure compensation can be used, but the built-in flash and optional flash units will not fire.

1 Set focus and exposure.

Frame the start of the panorama and press the shutter-release button halfway. Guides will appear in the display.

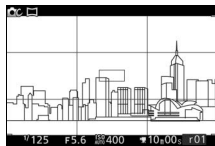

2 Start shooting.

Press the shutter-release button the rest of the way down and then lift your finger from the button. ▲, ▼, ◀, and ▶ icons will appear in the display to indicate the possible pan directions.

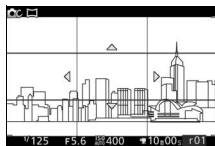



3 Pan the camera.

Slowly pan the camera up, down, left, or right as shown below. Shooting will start when the camera detects the pan direction and a progress indicator will appear in the display. Shooting ends automatically when the end of the panorama is reached.

Progress indicator



An example of how to pan the camera is shown below. Without changing your position, pan the camera in a steady curve either horizontally or vertically. Time the pan according to the option selected for **Image size** in the shooting menu: about 15 seconds are needed to complete the pan when  **Normal panorama** is selected, about 30 seconds when  **Wide panorama** is selected.

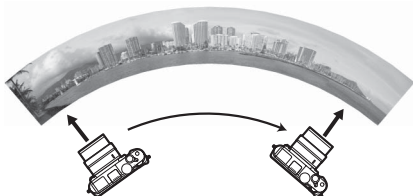

Panoramas

High-distortion wide-angle lenses may fail to produce the desired results. An error message will be displayed if the camera is panned too quickly or unsteadily. Note that because panoramas are composed of multiple images, the joins between images may be visible and the desired results may not be achieved with moving subjects or with neon lights or other subjects that exhibit rapid changes in color or brightness, subjects that are too close to the camera, poorly-lit subjects, and subjects such as the sky or sea that are a solid color or contain simple repeating patterns.

The completed panorama will be slightly smaller than the area visible in the display during shooting. No panorama will be recorded if shooting ends before the halfway point; if shooting ends after the halfway point but before the panorama is complete, the unrecorded portion will be shown in gray.

■ Viewing Panoramas

Panoramas can be viewed by pressing **OK** when a panorama is displayed full frame (35). The start of the panorama will be displayed with the smallest dimension filling the display and the camera will then scroll through the picture in the original pan direction.

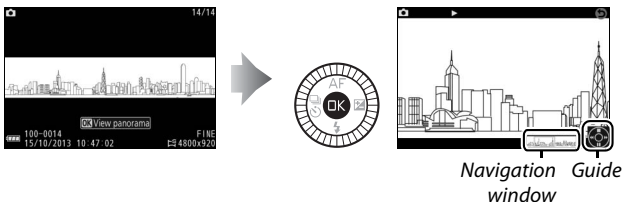

The following operations can be performed:

To	Use	Description
Pause		Pause playback.
Play		Resume playback when the panorama is paused or during rewind/advance.
Advance/ rewind		Press ◀ to rewind, ▶ to advance. If playback is paused, the panorama rewinds or advances a segment at a time; keep the button pressed for continuous rewind or advance. You can also rotate the multi selector to rewind or advance when playback is paused.
Return to full-frame playback		Press ▲ or ▶ to exit to full-frame playback.

Selective Color

Take black-and-white pictures in which one hue appears in a color.

1 Choose Select color.

Press **F** (feature) to display the **F** menu, then highlight **Select color** and press **OK**.



2 Choose a color.

Use the multi selector to choose a color and press **OK**.

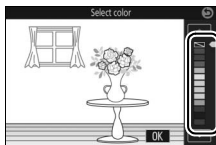

3 Take pictures.

Press the shutter-release button all the way down to take pictures. Only the selected hue will appear in color; all other hues will be recorded in shades of gray.



Cross Process

Select a base hue to take pictures with modified colors.

1 Select Hue.

Press **F** (feature) to display the **F** menu, then highlight **Hue** and press **OK**.



2 Choose a color.

Use the multi selector to choose a base color (red, green, blue, or yellow) and press **OK**.

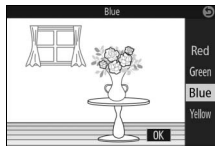

3 Take pictures.

Press the shutter-release button all the way down to take pictures with modified colors.



Recording and Viewing Movies

Recording Movies



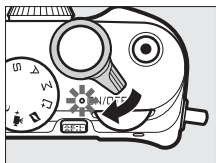

Movies can be recorded using the movie-record button.

1 Turn the camera on.

Rotate the power switch to turn the camera on.



2 Choose a shooting mode.

Rotate the mode dial to  (auto),  (creative), P, S, A, M, or + (advanced movie) as described on page 50. In advanced movie mode, you can choose a movie type using the **Advanced movie** option in the  menu (📖 51).

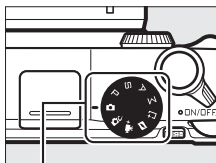

Mode dial

3 Frame the opening shot.

Frame the opening shot with your subject in the center of the display. If **Slow motion** is selected in advanced movie mode (📖 51), press the shutter-release button halfway to focus.

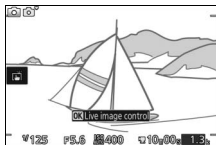

The icon

A  icon indicates that movies can not be recorded.

4 Start recording.

Press the movie-record button to begin recording. A recording indicator, the time elapsed, and the time available are displayed while recording is in progress.

Audio Recording

Be careful not to cover the microphone and note that the built-in microphone may record sounds made by the camera or lens. Except when recording slow-motion movies, the camera focuses continuously; to avoid recording focus noise, select **Single AF** for **Focus mode** in the movie menu (☞ 101).

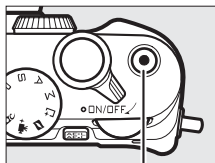

Movie-record button

*Recording indicator/
Time elapsed*

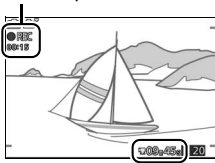

Time available

5 End recording.

Press the movie-record button again to end recording. Recording will end automatically when the maximum length is reached, the memory card is full, another mode is selected, the lens is removed, or the camera becomes hot (☞ xii).

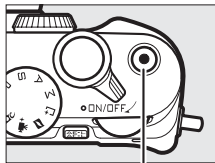

Movie-record button

Maximum Length

The camera can record movies up to 4 GB in size; note that depending on memory card write speed, shooting may end before this length is reached (☞ 111).



■ Shooting Mode

Movies can be recorded in the shooting modes listed below. Movies can not be recorded in best moment capture or Motion Snapshot modes.

📷 Auto mode (📖 31)

Choose this mode to leave the camera in charge of choosing settings. The camera automatically adjusts settings according to the subject and situation.

📷 Creative mode (📖 39)

Record movies in exposure mode **P** (programmed auto). If **Creative Palette** is selected, the chosen effect will be applied to the movie (📖 41).

📷+ Advanced movie mode (📖 51)

Choose an exposure mode (📖 100) and adjust shutter speed or aperture, or record movies in slow or fast motion or with other special effects.

P, S, A, and M modes (📖 56)



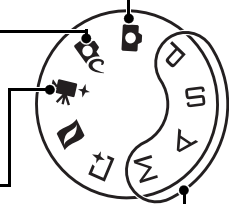





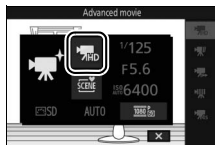

Movies shot when **S**, **A**, or **M** is selected are recorded in exposure mode **P**. Exposure mode selection is available only in advanced movie mode.



■ Advanced Movie Options

In  (advanced movie) mode, the following options can be accessed by pressing **F** (feature) and selecting **Advanced movie** in the **F** menu.



 HD movie	Record high-definition (HD) movies.
 Slow motion	Record up to about three seconds of silent slow-motion footage. Slow-motion movies are recorded at 400 fps and play back at about 30 fps. <i>Recording</i>  <i>Playback</i> 
 Fast motion	Record silent fast-motion footage that plays back at about four times normal speed. Playback time is one quarter the recording time. <i>Recording</i>  <i>Playback</i> 
 Jump cut	Record silent jump-cut movies. Recording pauses every other second for a drop-frame effect. <i>Recording</i>  <i>Playback</i> 
 4-second movie	Record a 4-second movie clip. Multiple clips can be joined into a single movie using the Combine 4-second movies option in the playback menu (□ 98).

Slow Motion

When slow motion is selected in advanced movie mode, the camera can be focused by pressing the shutter-release button halfway before recording begins. The camera focuses on the subject at the center of the display; face detection (□ 34) is not available. Focus and exposure can not be adjusted during recording.



Taking Photographs During Movie Recording

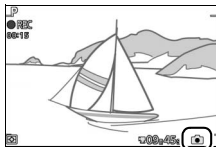

Press the shutter-release button all the way down to take a photograph without interrupting movie recording. Photographs taken during movie recording have an aspect ratio of 3 : 2.



Taking Photographs During Movie Recording

Up to 20 photographs can be taken with each movie shot. Please note that photographs can not be taken with slow-motion movies.

Viewing Movies

Movies are indicated by a  icon in full-frame playback (35). Press  to start playback.







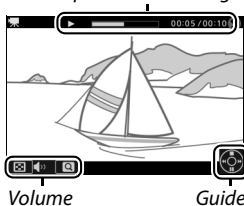



 icon/Length



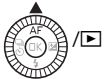

Movie playback indicator/
Current position/total length



The following operations can be performed:

To	Use	Description
Pause		Pause playback.
Play		Resume playback when the movie is paused or during rewind/advance.
Advance/ rewind	 	Press  to rewind,  to advance. Speed increases with each press, from 2x to 4x to 8x to 16x. If playback is paused, the movie rewinds or advances one frame at a time; keep the button pressed for continuous rewind or advance. You can also rotate the multi selector to rewind or advance when playback is paused.
Adjust volume		Rotate the main command dial to adjust volume.
Return to full-frame playback	 / 	Press  or  to exit to full-frame playback.

Deleting Movies

To delete the current movie, press . A confirmation dialog will be displayed; press  again to delete the movie and return to playback, or press  to exit without deleting the movie. *Note that once deleted, movies can not be recovered.*

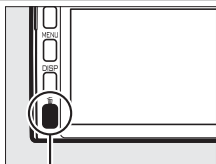

 button

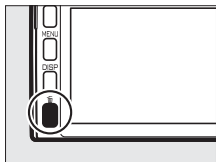
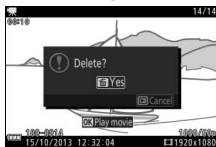

The Speaker

Keep your fingers and other objects away from the speaker when adjusting the volume.

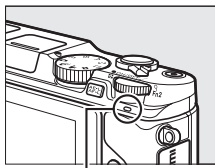

Speaker

Recording Time

The following table lists the approximate maximum recording times for individual movies shot at the default frame size and rate in each shooting mode.

Auto, creative, P, S, A, and M modes	10 minutes
Advanced movie mode	
HD movie	10 minutes
Slow motion	3 seconds
Fast motion	20 minutes
Jump cut	20 minutes
4-second movie	4 seconds

Recording Movies

Flicker, banding, or distortion may be visible in the display and in the final movie under fluorescent, mercury vapor, or sodium lamps or if the camera is panned horizontally or an object moves at high speed through frame (flicker and banding can be reduced by choosing a **Flicker reduction** option that matches the frequency of the local AC power supply, but note that the slowest shutter speed available is $\frac{1}{100}$ s at **50 Hz**, $\frac{1}{60}$ s at **60 Hz**; flicker reduction is not available with slow-motion movies). Bright light sources may leave after-images when the camera is panned. Jagged edges, color fringing, moiré, and bright spots may also appear. When recording movies, avoid pointing the camera at the sun or other strong light sources. Failure to observe this precaution could result in damage to the camera's internal circuitry. The built-in flash and optional flash units will not fire during movie recording or when the camera is in advanced movie mode.



P, S, A, and M Modes

P, S, A, and M modes offer varying degrees of control over shutter speed and aperture. Choose a mode and adjust settings according to your creative intent.

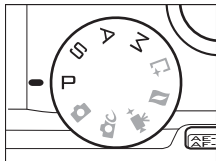

P Programmed Auto

In this mode, the camera automatically adjusts shutter speed and aperture for optimal exposure in most situations. This mode is recommended for snapshots and other situations in which you want to leave the camera in charge of shutter speed and aperture.

Choosing a Combination of Shutter Speed and Aperture

Although the shutter speed and aperture chosen by the camera will produce optimal results, you can also rotate the main command dial to choose other combinations that will produce the same exposure (“flexible program”). * is displayed while flexible program is in effect.

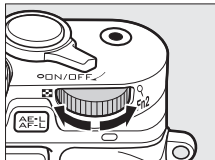

Main command dial

ISO Sensitivity (P, S, A, and M Modes)

When an “auto” option is selected for **ISO sensitivity** in the image processing menu (☐ 101), the camera will automatically adjust sensitivity within the selected range if optimal exposure can not be achieved at the selected shutter speed or aperture.

S Shutter-Priority Auto

In shutter-priority auto, you choose the shutter speed while the camera automatically selects the aperture that will produce the optimal exposure. Use slow shutter speeds to suggest motion by blurring moving subjects, fast shutter speeds to “freeze” motion.



Fast shutter speed ($1/1600$ s)

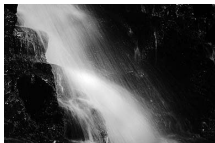

Slow shutter speed (1 s)

Choosing a Shutter Speed

Rotate the main command dial right for faster shutter speeds, left for slower shutter speeds. Choose from values between 30 s and $1/4000$ s. The electronic shutter, which can be enabled either by selecting **On** for **Silent photography** in the setup menu (📖 102) or by choosing a frame rate of 10, 20, 30, or 60 fps in continuous shooting mode (📖 75), supports shutter speeds as fast as $1/16,000$ s; the slowest shutter speed available with the electronic shutter is 30 s (silent photography) or $1/60$ s (10, 20, 30, and 60 fps continuous).

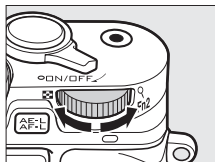

Main command dial

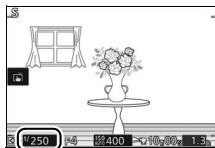

Continuous Shooting

The selected shutter speed may change when a frame rate of 10 fps or faster is selected in continuous shooting mode (📖 75).

A Aperture-Priority Auto

In aperture-priority auto, you choose the aperture while the camera automatically selects the shutter speed that will produce the optimal exposure. Large apertures (low f-numbers) reduce depth of field, blurring objects behind and in front of the main subject. Small apertures (high f-numbers) increase depth of field, bringing out details in the background and foreground. Short field depths are generally used in portraits to blur background details, long field depths in landscape photographs to bring the foreground and background into focus.



Large aperture (f/5.6)



Small aperture (f/16)

■ ■ Choosing an Aperture

Aperture is selected by rotating the sub-command dial: choose from values between the minimum and maximum for the lens.

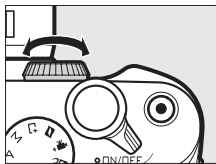

Sub-command dial

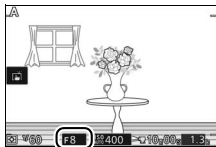

M Manual

In manual mode, you control both shutter speed and aperture.

■ Choosing Shutter Speed and Aperture

Adjust shutter speed and aperture with reference to the exposure indicator (📖 60). Shutter speed is set by rotating the main command dial right for faster speeds and left for slower speeds: choose from values between 30 s and $\frac{1}{4000}$ s (30 s and $\frac{1}{16,000}$ s when the electronic shutter is enabled by selecting **On** for **Silent photography** in the setup menu (📖 102), or $\frac{1}{60}$ s and $\frac{1}{16,000}$ s when the electronic shutter is enabled by selecting a frame rate of 10, 20, 30, or 60 fps in continuous shooting mode; 📖 75), or select “Bulb” to hold the shutter open indefinitely for a long time-exposure. Aperture is selected by rotating the sub-command dial: choose from values between the minimum and maximum for the lens.

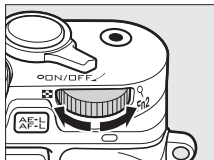

Main command dial

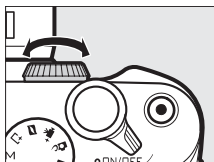

Sub-command dial

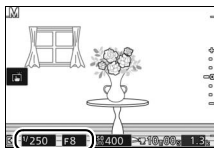

📌 Continuous Shooting

The selected shutter speed may change when a frame rate of 10 fps or faster is selected in continuous shooting mode (📖 75).

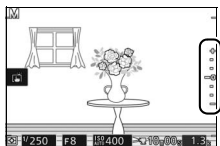

The Exposure Indicator

When shutter speeds other than “Bulb” or “Time” are selected, the exposure indicator shows whether the photograph would be under- or over-exposed at current settings.





Optimal exposure	Underexposed by $\frac{1}{3}$ EV	Overexposed by over 2 EV
+ . . -0 . . -	+ . . =0 . . -	+ =0 . . . -

Other Shooting Modes

In addition to the modes described above, the camera offers  (best moment capture) mode to help with hard-to-time shots and a  (Motion Snapshot) mode that combines photographs with brief movie vignettes ( 71).

Choosing the Moment (Best Moment Capture)

Choose a shot from 40 frames recorded to temporary storage shortly before or after the shutter is released (Active Selection), choose the moment to release the shutter as the scene plays back in slow motion (slow view,  65), or let the camera choose the best shot based on composition and movement (Smart Photo Selector,  67).

Choosing a Shot Manually (Active Selection)

Choose up to 40 shots from 40 frames recorded shortly before or after the shutter-release button is pressed all the way down.

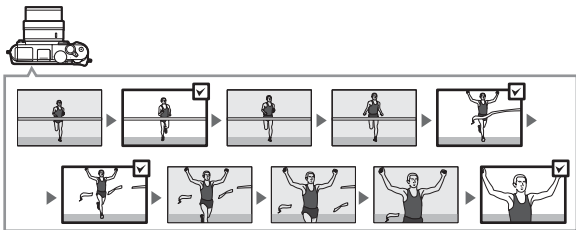

1 Select mode.

Rotate the mode dial to  (best moment capture).

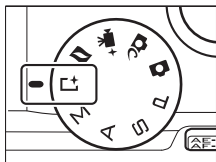

2 Choose Active Selection.

Press **F** (feature) to display the **F** menu. Highlight **Best moment capture** and press **OK**, then highlight **Active Selection** and press **OK**.

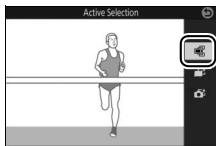

3 Frame the photograph.

Compose the photograph with your subject in the center of the frame.

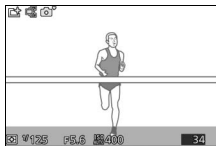

4 Begin buffering photographs.

Press the shutter-release button half-way to focus (📖 33). A  icon will be displayed as the camera begins recording images to the memory buffer.

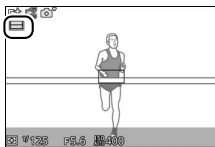







5 Shoot.

Smoothly press the shutter-release button the rest of the way down. The 40 frames recorded to the buffer in the moments before and after the shutter-release button was pressed all the way down will be copied to temporary storage.



6 Select up to 40 frames.

Press  or  or rotate the multi-selector to scroll through the frames and press  or  to select or deselect. Selected images are indicated by a  icon, while the remaining images are marked with  icons to show that they will be deleted.

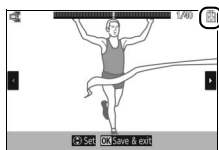

7 Save the selected frames.

Press  to save the selected frames to the memory card. The memory card access lamp will light while recording is in progress; note that depending on shooting conditions and memory card write speed, some time may be required to save the selected images.

Active Selection

At default settings, the frame recorded at the moment the shutter-release button was pressed all the way down is automatically marked with a  icon in Step 6.

Best Moment Capture Mode

Movies can not be recorded, and pressing the movie-record button has no effect. The built-in flash and optional flash units can not be used.



Choosing Your Moment (Slow View)

When slow view is selected in  (best moment capture) mode, the camera captures a short sequence of still images and plays them back in slow motion so that you can choose the precise moment for a photograph.

1 Select mode.

Rotate the mode dial to  (best moment capture).

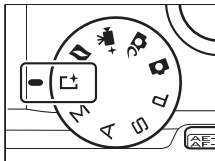

2 Select Slow view.

Press **F** (feature) to display the **F** menu. Highlight **Best moment capture** and press **OK**, then highlight **Slow view** and press **OK**.

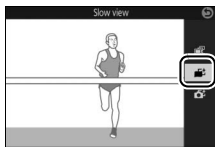

3 Frame the photograph.

Compose the photograph with your subject in the center of the frame.

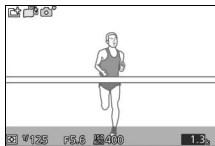

4 Press the shutter-release button halfway.

After focusing, the camera will record 40 frames to a temporary memory buffer. It will then slowly play them back in a continuous loop while the shutter-release button is kept pressed halfway. A  icon is displayed in the monitor.



Progress indicator



When the desired frame is displayed, press the shutter-release button the rest of the way down to record the current frame and discard the remaining images. The selected frame will be displayed for a few seconds when recording is complete. To delete the buffer contents and exit without recording a photograph, release the button without pressing it the rest of the way down.

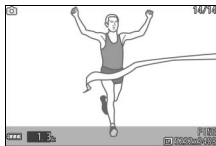

Letting the Camera Choose the Moment (Smart Photo Selector)

The Smart Photo Selector helps you capture a fleeting expression on the face of a portrait subject or other hard-to-time shots such as group photos in party scenes. Each time the shutter is released, the camera automatically selects the best shot and four best shot candidates based on composition and motion.



1 Select mode.

Rotate the mode dial to  (best moment capture).

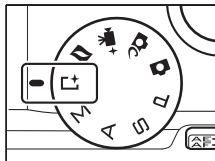

2 Choose Smart Photo Selector.

Press **F** (feature) to display the **F** menu. Highlight **Best moment capture** and press **OK**, then highlight **Smart Photo Selector** and press **OK**.

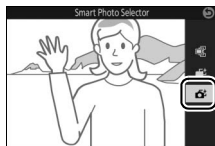
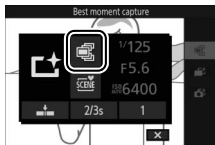

3 Frame the photograph.

Compose the photograph with your subject in the center of the frame.

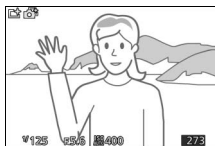

4 Begin buffering photographs.

Press the shutter-release button half-way to focus (33). A  icon will be displayed as the camera begins recording images to the memory buffer. The camera continuously adjusts focus to account for changes in the distance to the subject while the shutter-release button is pressed halfway.

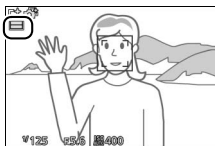

5 Shoot.



Smoothly press the shutter-release button the rest of the way down. The camera will compare shots recorded to the buffer both before and after the shutter-release button was pressed all the way down, and select five to copy to the memory card. Note that some time may be required. The best picture is displayed in the monitor when recording is complete.



Smart Photo Selector



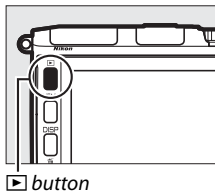

The camera automatically chooses a scene mode appropriate to the subject.

■ Viewing Photos Taken with the Smart Photo Selector

Press  and use the multi selector to display photographs taken with the Smart Photo Selector (📖 35; pictures taken with the Smart Photo Selector are indicated by a  icon). Of the photographs recorded by the Smart Photo Selector, only the best shot will be displayed (when you press  to view the next picture, the camera will skip over the best shot candidates, with the result that the next picture displayed will not have a file number that immediately follows that of the current picture). To end playback and return to shooting mode, press the shutter-release button halfway.





Choosing the Best Shot

When a photograph taken with the Smart Photo Selector is displayed, you can choose the best shot by pressing . Press  or  to view the other pictures in the sequence and press  to select the current picture as the best shot. To return to normal playback, press .



■ Deleting Pictures

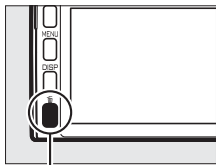

Pressing  when a picture taken with the Smart Photo Selector is selected displays a confirmation dialog; press  again to delete the best shot and the best shot candidates, or press  to exit without deleting the pictures. *Note that once deleted, pictures can not be recovered.*

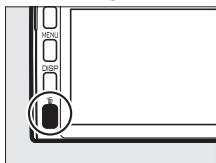

 button



Deleting Individual Photographs

Pressing the  button in the best shot selection dialog displays the following options; highlight an option using the multi selector and press  to select.

- **This image:** Delete the current photo (note that the picture currently selected as the best shot can not be deleted).
- **All except best shot:** Delete the best shot candidates, but not picture currently selected as the best shot.

A confirmation dialog will be displayed; to delete the selected image or images, highlight **Yes** and press .

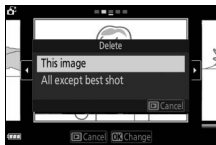

📷 Combining Photos with Brief Movie Vignettes (Motion Snapshot Mode)

Record brief movie vignettes with your photographs. Each time the shutter is released, the camera records a still image and about 1.6 s of movie footage. When the resulting “Motion Snapshot” is viewed on the camera, the movie will play back in slow motion over approximately 4 s, followed by the still image.

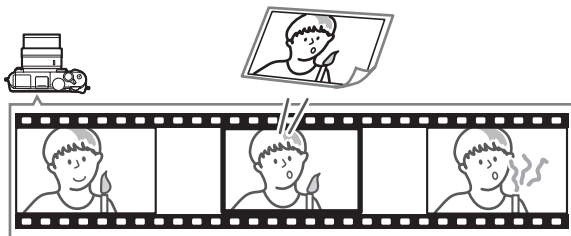

1 Select 📷 mode.

Rotate the mode dial to 📷 (Motion Snapshot).

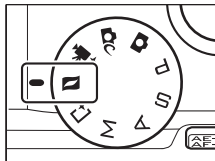

2 Frame the picture.

Compose the photograph with your subject in the center of the frame.



3 Begin buffering.

Press the shutter-release button half-way to focus (□ 33). A □ icon will be displayed as the camera begins recording footage to the memory buffer.



4 Shoot.

Smoothly press the shutter-release button the rest of the way down. The camera will record a photograph, together with about 1.6 s of movie footage beginning before and ending after the time the shutter-release button was pressed all the way down. Note that some time may be required. When recording is complete, the photograph will be displayed for a few seconds.



Ending the Vignette with a Photograph

To make the photograph the same as the last frame in the movie vignette, select **1.6 s : 0 s** for **Movie before/after** in the shooting menu (□ 99).

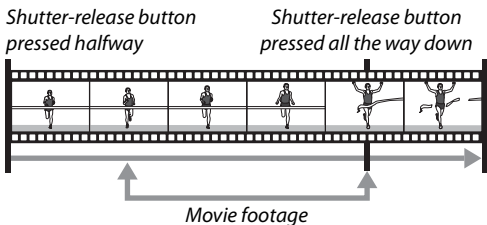

■ Audio

To record about four seconds of sound with Motion Snapshots beginning at the start of movie recording, use the multi-selector and **OK** button to select **Ambient** for **Audio** in the **F** (feature) menu (📖 10). Motion Snapshots can also be recorded with background music (**Background music**) or no sound (**None**).

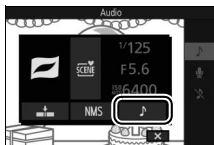





📌 Motion Snapshot Mode

Movies can not be recorded using the movie-record button and the built-in flash and optional flash units can not be used.



Viewing Motion Snapshots

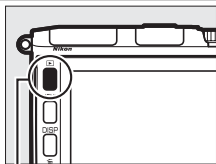

Press  and use the multi selector to display a Motion Snapshot ( 35; Motion Snapshots are indicated by a  icon). Pressing  when a Motion Snapshot is displayed plays back the movie portion in slow motion over a period of about 4 s, followed by the photo; playback is accompanied by the audio track selected using the **Audio** option ( 73). To end playback and return to shooting mode, press the shutter-release button halfway.



 button



Deleting Motion Snapshots

To delete the current Motion Snapshot, press . A confirmation dialog will be displayed; press  again to delete the photo and movie and return to playback, or press  to exit without deleting the file. *Note that once deleted, Motion Snapshots can not be recovered.*

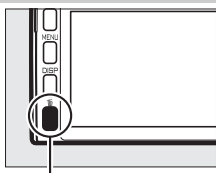

 button

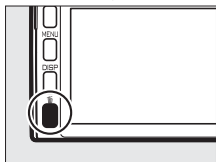
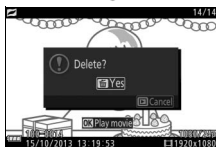



More on Photography

This section describes other features you can use when taking pictures.

Continuous Mode

Shoot a continuous series (burst) of photographs.

1 Display release mode options.

Press ◀ (S) to display release mode options.

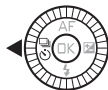





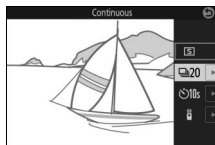

2 Select .

Highlight  (continuous) and press ▶ to display frame rate options.



3 Select a frame rate.

Highlight the desired frame rate and press (OK). Frame rate is expressed in terms of the number of frames recorded per second (fps); choose from frame rates of approximately 6, 10, 20, 30, and 60 fps (, , , , and , respectively). Except when  is selected, the maximum number of shots that can be recorded in a single burst is 40.

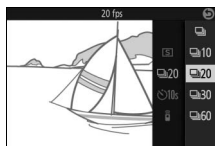



4 Frame your subject and shoot.

Press the shutter-release button all the way down to shoot the burst.





Continuous Mode

A mechanical shutter is used for pictures taken when  is selected and **Off** is selected for **Silent photography** in the setup menu (102). An electronic shutter is used for pictures taken at other settings. If the built-in flash or optional flash unit fires when  is selected, only one picture will be taken; at settings of 10, 20, 30, and 60 fps, the built-in flash and optional flash units will not fire.

While photographs are being recorded to the memory card, the memory card access lamp will light. Depending on shooting conditions and memory card write speed, recording may take some time. If the battery is exhausted before all photographs are recorded, the shutter release will be disabled and the remaining images transferred to the memory card.

Continuous shooting is not available in creative, best moment capture, advanced movie, or Motion Snapshot mode or when live image control is used in auto mode (37).

Single Frame

To take only one picture each time the shutter-release button is pressed all the way down, press  () and select  (single frame) for release mode.

Self-Timer Modes

The self-timer is used to delay shutter release until 10 or 2 seconds after the shutter-release button is pressed all the way down.

1 Display release mode options.

Press ◀ (📄) to display release mode options.

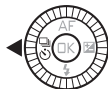

2 Select 🕒.

Highlight 🕒 (self-timer) and press ▶ to display self-timer options.



3 Select the desired self-timer option.

Use the multi selector to highlight 🕒10s or 🕒2s and press (OK).

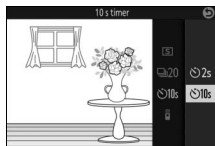

4 Mount the camera on a tripod.

Mount the camera on a tripod or place the camera on a stable, level surface.



5 Frame the photograph and shoot.

Press the shutter-release button half-way to focus, and then press the button the rest of the way down. The self-timer lamp will start to flash and a beep will begin to sound. Two seconds before the photo is taken, the lamp will stop flashing and the beeping will become more rapid.

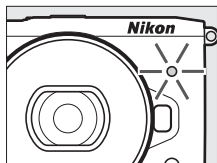

Note that the timer may not start or a photograph may not be taken if the camera is unable to focus or in other situations in which the shutter can not be released. Turning the camera off cancels the self-timer.



Movie Mode

To record movies using the self-timer, select advanced movie mode and use the movie-record button to start the timer. Movie recording ends when the movie-record button is pressed a second time.

Raising the Flash

When using the built-in flash, press the flash pop-up button to raise the flash before shooting. Shooting will be interrupted if the flash is raised while the timer is counting down.

Remote Control Photography

The optional ML-L3 remote control (📖 110) can be used to reduce camera shake or for self-portraits.

🔧 Before Using the ML-L3 Remote Control

Before using the remote control for the first time, remove the clear plastic battery-insulator sheet.

1 Display release mode options.

Press ◀ (📷) to display release mode options.



2 Select 📷.

Highlight 📷 (remote control) and press ▶ to display remote control options.



3 Select the desired remote-control option.

Use the multi selector to highlight 📷 or 📷 2s and press (OK).

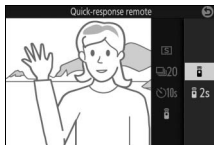

4 Mount the camera on a tripod.

Mount the camera on a tripod or place the camera on a stable, level surface.



5 Frame the photograph and shoot.

From a distance of 5 m (16 ft) or less, aim the ML-L3 at the infrared receiver on the front of the camera (☞ 2) and press the ML-L3 shutter-release button. If 2s is selected, the self-timer lamp will light for about two seconds before the shutter is released. If $\text{}$ is selected, the self-timer lamp will flash after the shutter has been released.

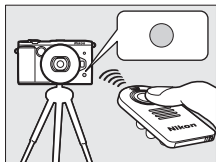

Note that the timer may not start or a photograph may not be taken if the camera is unable to focus or in other situations in which the shutter can not be released. Turning the camera off cancels remote control mode. Remote control mode is cancelled automatically if no operations are performed for about ten minutes after the mode is selected in Step 3.



Movie Mode

The ML-L3 shutter-release button functions as the movie-record button for advanced movie mode (☞ 48).

Using a Flash

When using the built-in flash, press the flash pop-up button to raise the flash before shooting. Shooting will be interrupted if the flash is raised while the delayed-remote timer is counting down.

In remote control mode, the flash starts charging while the camera is waiting for the signal from the remote. The camera will only respond to the shutter-release button on the remote control when the flash is charged. If red-eye reduction (☞ 82) is used when $\text{}$ is selected, the shutter will be released about one second after the red-eye reduction lamp lights. If 2s is selected, there will be about a two second delay after the shutter-release button on the remote control is pressed; the red-eye reduction lamp will then light for about one second before the shutter is released.

The Built-in Flash

Use the built-in flash for additional lighting when the subject is poorly lit or to “fill-in” (illuminate) back-lit subjects. The built-in flash can be used as described below, but note that some camera settings automatically disable the built-in flash:

1 Raise the flash.

Press the flash pop-up button to raise the flash.

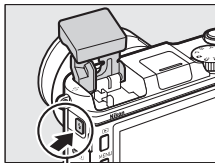

Flash pop-up button

2 Choose a flash mode.

Press ▼ (⚡) on the multi selector to display a list of flash modes, then use the multi selector to highlight the desired mode and press OK to select.

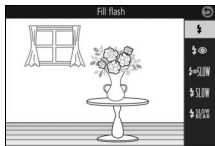













3 Take pictures.

The flash will fire with every shot. To disable the flash, press it gently downward until it latches.



■ Flash Modes

The following flash modes are available in  (auto),  (soft),  (miniature effect),  (selective color),  (cross process),  (toy camera effect), P, S, A, and M modes:

-  (fill flash): The flash fires with every shot.
-  (red-eye reduction): Use for portraits. The flash fires with every shot, but before it fires, the red-eye reduction lamp lights to help reduce “red-eye.”
-  SLOW (red-eye reduction with slow sync): As for “red-eye reduction”, above, except that shutter speed slows automatically to capture background lighting at night or under low light. Use when you want to include background lighting in portraits. Available only in modes P and A.
-  SLOW (fill flash + slow sync): As for “fill flash”, above, except that shutter speed slows automatically to capture background lighting at night or under low light. Use when you want to capture both subject and background. Available only in modes P and A.
-  SLOW REAR (rear curtain + slow sync): As for “rear-curtain sync”, below, except that shutter speed slows automatically to capture background lighting at night or under low light. Use when you want to capture both subject and background. Available only in modes P and A.
-  REAR (rear-curtain sync): The flash fires just before the shutter closes, creating a stream of light behind moving light sources as shown below at right. Available only in modes S and M.



Front-curtain sync



Rear-curtain sync

✓ Raising the Flash

When using the flash, be sure it is fully raised as shown at right. Do not touch the flash during shooting.

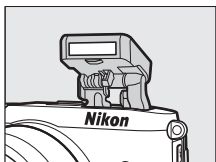

✎ Lowering the Built-in Flash

To save power when the flash is not in use, press it gently downward until the latch clicks into place. *Do not use force.* Failure to observe this precaution could result in product malfunction.

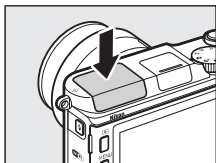

✎ The Flash-Ready Indicator

The flash-ready indicator (⚡) lights to show that the flash is fully charged when the shutter-release button is pressed halfway.



Using the Built-in Flash

If the flash is fired multiple times in quick succession, the flash and shutter may be temporarily disabled to protect the flash. Shooting can be resumed after a brief pause.

Objects close to the camera may be overexposed in photographs taken with the flash at high ISO sensitivities.

To avoid vignetting, remove lens hoods and shoot at ranges of at least 0.6 m (2 ft). Some lenses may cause vignetting at greater distances or obstruct the red-eye reduction lamp, interfering with red-eye reduction. The following illustrations show the effect of vignetting caused by shadows cast by the lens when the built-in flash is used.

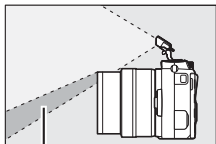

Shadow



Shadow

Aperture, Sensitivity, and Flash Range

Flash range varies with sensitivity (ISO equivalency) and aperture.



Tap Shooting Options

Tap the icon shown at right to choose the operation performed by tapping the monitor in shooting mode. The options available vary with the shooting and focus mode.

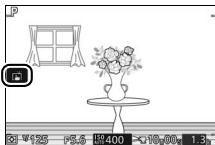

Auto and Creative Modes

Choose from the following options.

	When you tap a subject in the display, the camera will focus and take a picture.
	Tapping the display during shooting has no effect.

P, S, A, and M Modes

The operation performed by tapping the display depends on whether the camera is in autofocus or manual focus mode.





Autofocus Modes

The following options are available in autofocus modes (AF-A, AF-S, and AF-C).

	When you tap a subject in the display, the camera will focus and take a picture.
	Tap the display to position the focus area when single-point AF is selected for AF-area mode. To focus, press the shutter-release button halfway.
	Tap a subject to start tracking when subject tracking is selected for AF-area mode.
	Tapping the display during shooting has no effect.

Manual Focus Mode

The following options are available in manual focus mode.



	When you tap the display, the camera will take a picture without first adjusting focus.
	Tap a subject to display it at a higher magnification in the monitor.
	Tapping the display during shooting has no effect.

Advanced Movie Mode

The operation performed by tapping the display depends on whether the camera is in autofocus or manual focus mode.



Autofocus Modes

The following options are available in autofocus modes (AF-F and AF-S).

	To focus when auto-area AF or single-point AF is selected for AF-area mode, tap your subject in the display.
	Tap a subject to start tracking when subject tracking is selected for AF-area mode.
	Tapping the display during shooting has no effect.

Manual Focus Mode

The following options are available in manual focus mode.



	Tap a subject to display it at a higher magnification in the monitor.
	Tapping the display during shooting has no effect.

Best Moment Capture/Motion Snapshot

Tap shooting options are not available in best moment capture and Motion Snapshot modes.

Taking Pictures Using Tap Shooting Options

Avoid tapping too hard. The camera may move when the shutter is released, blurring photographs.

The shutter-release button can be used to focus and take pictures even when the  icon is displayed to show that tap shooting options are active. Use the shutter-release button to take photographs in continuous shooting mode ( 75) and during movie recording. Tap shooting options can be used only to take pictures one at a time in continuous shooting mode and can not be used to take photographs during movie recording. In self-timer mode ( 77), tapping the monitor locks focus and starts the timer; the photograph will be taken after ten or two seconds.



Wi-Fi

What Wi-Fi Can Do for You

The camera can connect via Wi-Fi wireless networks to a smart device running Nikon's dedicated Wireless Mobile Utility app. The smart device can be used to control the camera and take pictures remotely, or pictures can be downloaded from the camera to the smart device and shared with others on the Internet. Pictures can also be uploaded from the camera to the smart device (📖 94).

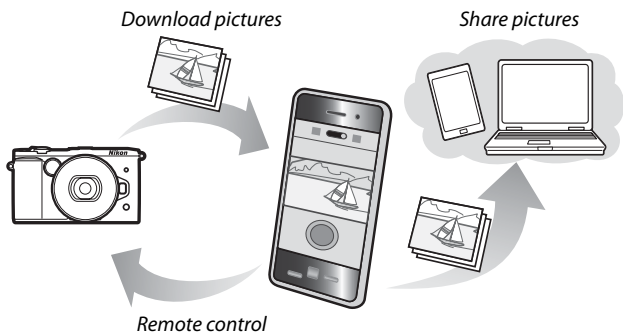

🔍 Installing the Wireless Mobile Utility App

1 Find the app.

On the smart device, connect to the Google Play service, the App Store, or another app marketplace and search for "Wireless Mobile Utility". For more information, see the instructions provided with the smart device.

2 Install the app.

Read the app description and install the app. A pdf manual for the Wireless Mobile Utility is available for download at the following URLs:

- **Android:** <http://nikonimglib.com/ManDL/WMAU/>
- **iOS:** <http://nikonimglib.com/ManDL/WMAU-ios/>

Accessing the Camera

Before connecting via Wi-Fi (wireless LAN), install the Wireless Mobile Utility on your Android or iOS smart device. Instructions for accessing the camera vary with the type of connection used by the smart device.

Android

- **Push-button WPS:** If the smart device supports push-button WPS (i.e., has a **WPS button connection** option in its **Wi-Fi settings** menu), you can use this easy method to connect to the smart device (📖 90)
- **PIN-entry WPS:** If the smart device supports WPS, you can use the camera to establish a connection by entering the PIN displayed by the smart device (📖 91)
- **View SSID:** If the smart device does not support WPS, you can connect by selecting the camera SSID on the smart device (📖 92)

iOS

- **View SSID:** Connect by selecting the camera SSID on the smart device (📖 92)

WPS

WPS (Wi-Fi Protected Setup) is a standard designed to make it easy to establish a secure wireless network. For information on the steps involved and the length of time the smart device will wait for a connection, see the documentation supplied with the smart device.



WPS (Android Only)

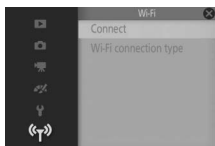

1 Select Wi-Fi.

Press the MENU button to display the menus, then highlight **Wi-Fi** and press .



2 Connect.

Enable WPS button connections on the camera and smart device:

- **Camera:** Highlight **Wi-Fi connection type** and press , then highlight **Push-button WPS** and press  to ready the camera for a WPS connection. The camera will wait about two minutes for a WPS connection request from the smart device. To extend the wait time, press .
- **Smart device:** Select **Wi-Fi settings** > **WPS button connection**.

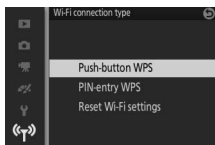
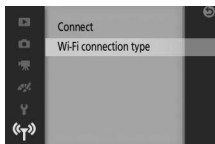

3 Launch the Wireless Mobile Utility.

Launch the Wireless Mobile Utility on the smart device. The main dialog will be displayed.

PIN Entry (Android Only)

1 Select Wi-Fi.

Press the MENU button to display the menus, then highlight **Wi-Fi** and press .

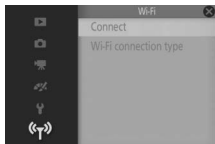

2 Select Wi-Fi connection type > PIN-entry WPS.





Highlight **Wi-Fi connection type** and press .



Highlight **PIN-entry WPS** and press .



3 Enter the PIN.

Enter the PIN displayed by the smart device. Press  or  to highlight digits and press  or  to change. Press  when entry is complete.

4 Launch the Wireless Mobile Utility.

Launch the Wireless Mobile Utility on the smart device. The main dialog will be displayed.

1 Select Wi-Fi.

Press the MENU button to display the menus, then highlight **Wi-Fi** and press .

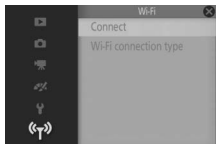

2 Select Connect.

Highlight **Connect** and press .



3 Select Yes.

Highlight **Yes** and press  to view the camera SSID.

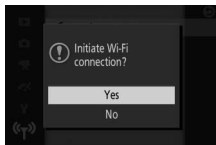

4 Select the camera SSID on the smart device.

Select the camera SSID in the list of networks displayed by the smart device.

5 Launch the Wireless Mobile Utility.

Launch the Wireless Mobile Utility on the smart device. The main dialog will be displayed.

■ Restoring Default Settings

To restore default network settings, highlight **Wi-Fi connection type** > **Reset Wi-Fi settings** and press ►. A confirmation dialog will be displayed; highlight **Yes** and press (OK) to restore default network settings.

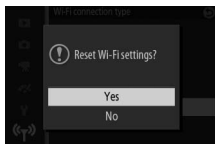

☑ Wi-Fi

Before using the Wi-Fi function, read the warnings on pages xiv to xvi; to prevent loss of power while connected, you should also charge the camera battery. Do not use Wi-Fi in settings in which its use is prohibited. Note that the camera Wi-Fi function can not be used when a USB or HDMI cable is connected.

☑ Terminating Wi-Fi Connections

Wi-Fi will terminate automatically if the smart device does not initiate a connection within five minutes. To terminate Wi-Fi manually, press the MENU button to exit the Wi-Fi standby or connection display.

☑ Electronic Viewfinders

Optional electronic viewfinders (□ 27) turn off while Wi-Fi is in use. The eye sensor turns on automatically when the Wi-Fi connection ends.



Uploading Pictures to a Smart Device

Follow the steps below to upload photos from the camera to a smart device.

Uploading Photos One at a Time

Use the **Wi-Fi upload** option in the playback **F** (feature) menu (📖 10) to upload the photo currently displayed in full-frame playback.

1 Display the photo on the camera.

Display the desired photo in full-frame playback.

2 Select Wi-Fi upload.

Press **F** (feature) to display the **F** menu, then highlight **Wi-Fi upload** and press **OK**. A confirmation dialog will be displayed.



3 Select Yes.

Highlight **Yes** and press **OK**. To upload multiple selected photos, choose **Select images from list** and proceed to Step 2 on page 96.

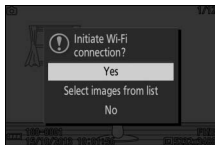

4 Select the camera SSID on the smart device.

Select the camera SSID in the list of networks displayed by the smart device.



5 Download the photo to the smart device.

Launch the Wireless Mobile Utility on the smart device and follow the on-screen instructions to download the photo. When download is complete, press the MENU button on the camera to terminate the Wi-Fi connection.



Uploading Multiple Selected Photos

To upload multiple selected photos, use the **Wi-Fi upload** option in the playback menu.

1 Choose Wi-Fi upload.

Press the MENU button to display the menus. Highlight **Wi-Fi upload** in the playback menu and press ►.

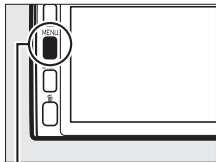

MENU button

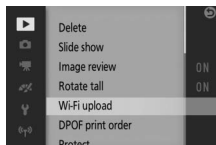

2 Select photos.

Press ◀ or ▶ to scroll through pictures and press ▲ or ▼ to select or deselect, or press and hold the main command dial to view the highlighted picture full frame. Selected images are indicated by a  icon.

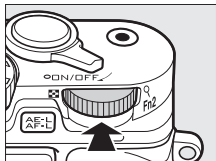

Main command dial

3 Press .

Press  to complete the operation. A confirmation dialog will be displayed.

4 Select **Yes**.

Highlight **Yes** and press .



5 Select the camera SSID on the smart device.

Select the camera SSID in the list of networks displayed by the smart device.

6 Download the photos to the smart device.

Launch the Wireless Mobile Utility on the smart device and follow the on-screen instructions to download the selected photos. When download is complete, press the MENU button on the camera to terminate the Wi-Fi connection.



Menu Options

To display the playback, shooting, movie, image processing, and setup menus, press the MENU button. Following menu options are available:

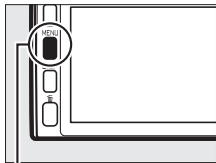

MENU button

■ Playback Menu Options

Option	Description
Delete	Delete multiple images.
Slide show	View movies and photos in a slide show.
Image review	Choose whether pictures are displayed after shooting.
Rotate tall	Rotate "tall" (portrait-orientation) pictures for display during playback.
Wi-Fi upload	Upload selected photos to smart devices via wireless networks.
DPOF print order	Create digital "print orders".
Protect	Protect pictures from accidental deletion.
Rating	Rate pictures.
D-Lighting	Brighten shadows in dark or back-lit photos, creating a retouched copy that is saved separately from the unmodified original.
Resize	Create small copies of selected pictures.
Crop	Create cropped copies of selected pictures.
Edit movie	Create copies of movies from which unwanted footage has been trimmed.
Combine 4-second movies	Combine multiple 4-second movies into a single movie.
Combine NMS movies	Make a movie from the movie portions of multiple Motion Snapshots.

■ Shooting Menu Options

Option	Description
Reset shooting options	Reset shooting options to default values.
Creative	Choose a creative mode.
Best moment capture	Choose from Active Selection , Slow view , and Smart Photo Selector .
Exposure mode	Choose how the camera sets shutter speed and aperture in Motion Snapshot mode and when Active Selection or Slow view is chosen in best moment capture mode.
Image quality	Choose a file format and compression ratio.
Image size	Choose a size for new photos.
Active Selection	Choose the frames Active Selection (☐ 61) records to temporary storage, the length of time over which the frames are captured, and the default number of frames saved.
Number of shots saved	Choose the number of shots selected by the Smart Photo Selector (☐ 67).
Movie before/after	Choose when the movie portion of Motion Snapshots is recorded (☐ 71).
File format	Choose a file format for new Motion Snapshots (☐ 71).
Audio	Choose the audio recorded with Motion Snapshots (☐ 71).
Select color	Choose the hue that appears in color in pictures taken with Selective color selected in creative mode.
Soft	Choose amount of softening applied to pictures taken with Soft selected in creative mode. You can also choose how softening applies to pictures with portrait subjects.



Option	Description
Hue	Choose base hue for pictures taken with Cross process selected in creative mode.
Toy camera effect	Adjust saturation and vignetting for pictures taken with Toy camera effect selected in creative mode.
Metering	Choose how the camera meters exposure.
Auto distortion control	Choose whether the camera corrects barrel and pin-cushion distortion.
Color space	Choose a color space for new pictures.
Active D-Lighting	Avoid loss of detail in highlights and shadows.
Long exposure NR	Reduce noise in long time-exposures.
Interval timer shooting	Take photos at a pre-selected interval.
Optical VR	Adjust settings for 1 NIKKOR lenses with vibration reduction.
Electronic VR	Choose whether to use electronic vibration reduction in Motion Snapshot mode (☐ 71).
Focus mode	Choose how the camera focuses.
AF-area mode	Choose how the focus area is selected.
Face-priority	Turn face priority on or off.
Built-in AF assist	Control the built-in AF-assist illuminator.
Flash control	Choose a flash mode for the built-in and optional flash units.
Flash compensation	Control flash output.

■■ Movie Menu Options

Option	Description
Reset movie options	Reset movie menu options to their default values.
Advanced movie	Choose a movie type for advanced movie mode.
Exposure mode	Choose how the camera sets exposure in advanced movie mode.

Option	Description
Slow motion	Choose a frame rate for slow-motion movies recorded in advanced movie mode (□ 51).
Frame size/ frame rate	Choose a frame size and rate for movies recorded in auto, creative, P, S, A, and M modes and when HD movie is selected in advanced movie mode (□ 51).
Metering	Choose how the camera meters exposure.
Movie sound options	Choose sound recording options.
Optical VR	Adjust settings for 1 NIKKOR lenses with vibration reduction.
Electronic VR	Choose whether to use electronic vibration control when recording movies.
Focus mode	Choose how the camera focuses.
AF-area mode	Choose how the focus area is selected.
Face-priority	Turn face priority on or off.
Auto image capture	Choose whether the camera takes photos automatically during movie recording and select the number of pictures taken per minute.

■■ Image Processing Menu Options

Option	Description
Reset processing options	Reset image processing options to their default values.
White balance	Adjust settings for different types of lighting.
ISO sensitivity	Control the camera's sensitivity to light.
Picture Control	Choose how the camera processes pictures.
Custom Picture Control	Create custom Picture Controls.
High ISO noise reduction	Reduce noise at high ISO sensitivities.



■ Setup Menu Options

Option	Description
Reset setup options	Reset setup menu options other than Flicker reduction, Time zone and date , and Language to default values.
Format memory card	Format the memory card.
Slot empty release lock	Allow the shutter to be released when no memory card is inserted in the camera.
Display	Adjust display brightness, view or hide a framing grid, and choose the information displayed in the monitor.
Silent photography	Mute the sounds made during shooting.
Sound settings	Choose the beeps made by the camera.
Auto power off	Choose the auto power off delay.
Touch-screen controls	Enable or disable touch-screen controls.
Remote on duration	Choose how long the camera waits for a signal from an ML-L3 remote control.
Assign Fn button	Choose the roles played by the Fn1 , Fn2 , and Fn3 buttons.
Assign AE/AF-L button	Choose the role played by the AE/AF-L button.
Shutter button AE lock	Choose whether exposure locks when the shutter-release button is pressed halfway.
HDMI device control	Choose whether remote controls for HDMI-CEC devices to which the camera is connected can be used to operate the camera.
Flicker reduction	Reduce flicker or banding.
Reset file numbering	Reset file numbering.
Time zone and date	Set the camera clock.
Language	Choose a language for the camera displays.
Auto image rotation	Record camera orientation with pictures.
Location data	Adjust settings for optional GPS units.
Pixel mapping	Check and optimize the camera image sensor and image processors.
Firmware version	Display the current firmware version.



Connecting to a Computer

Installing the Supplied Software

Install the supplied software to copy pictures to your computer for viewing and editing. Before installing the software, confirm that your system meets the requirements on page 104.

1 Launch the installer.

Start the computer, insert the ViewNX 2 installer CD, and launch the installer. A language-selection dialog will be displayed; if the desired language is not available, click **Region Selection** to choose a different region and then choose the desired language (region selection is not available in the European release).

2 Start the installer.

Click **Install** and follow the on-screen instructions.

3 Exit the installer.

Click **Yes** (Windows) or **OK** (Mac) when installation is complete.

4 Remove the installer CD from the CD-ROM drive.

Supplied Software

Be sure to update to the latest versions of the supplied software. Nikon Message Center 2 will periodically check for updates while the computer is connected to the Internet.

Motion Snapshots

ViewNX 2 is required to view Motion Snapshots saved using the **File format > NMS files** option in the shooting menu (☰ 99).

Supported Operating Systems

See the websites listed on page xiii for the latest information on supported operating systems.



System Requirements

The system requirements for ViewNX 2 are:

Windows	
CPU	<ul style="list-style-type: none">• Photos: Intel Celeron, Pentium 4, Core Series; 1.6 GHz or better• Movies (playback): Pentium D 3.0 GHz or better; Intel Core i5 or better recommended when viewing movies with a frame size of 1280 × 720 or more at a frame rate of 30 fps or above or movies with a frame size of 1920 × 1080 or more• Movies (editing): Intel Core i5 or better
OS	Pre-installed versions of Windows 8.1, Windows 7, or Windows Vista
Memory (RAM)	<ul style="list-style-type: none">• 32-bit Windows 8.1, Windows 7, or Windows Vista: 1 GB or more (2 GB or more recommended)• 64-bit Windows 8.1, Windows 7, or Windows Vista: 2 GB or more (4 GB or more recommended)
Hard disk space	A minimum of 1 GB available on the startup disk (3 GB or more recommended)
Graphics	<ul style="list-style-type: none">• Resolution: 1024 × 768 pixels (XGA) or more (1280 × 1024 pixels or more recommended)• Color: 24-bit color (True Color) or more



Mac	
CPU	<ul style="list-style-type: none"> • Photos: Intel Core or Xeon series • Movies (playback): Core Duo 2 GHz or better; Intel Core i5 or better recommended when viewing movies with a frame size of 1280 × 720 or more at a frame rate of 30 fps or above or movies with a frame size of 1920 × 1080 or more • Movies (editing): Intel Core i5 or better
OS	OS X 10.9, 10.8, or 10.7
Memory (RAM)	2 GB or more (4 GB or more recommended)
Hard disk space	A minimum of 1 GB available on the startup disk (3 GB or more recommended)
Graphics	<ul style="list-style-type: none"> • Resolution: 1024 × 768 pixels (XGA) or more (1280 × 1024 pixels or more recommended) • Color: 24-bit color (millions of colors) or more



Viewing and Editing Pictures on a Computer

Transferring Pictures

1 Choose how pictures will be copied to the computer.

Choose one of the following methods:

- **Direct USB connection:** Turn the camera off and ensure that the memory card is inserted in the camera. Connect the camera to the computer using the supplied USB cable (do not use force or insert the connectors at an angle) and then turn the camera on.

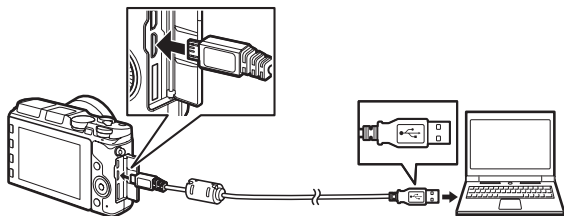

- **Card slot:** If your computer is equipped with a slot for microSD memory cards, the card can be inserted directly in the slot.
- **Card reader:** Connect a card reader (available separately from third-party suppliers) to the computer and insert the memory card.



2 Start the Nikon Transfer 2 component of ViewNX 2.

If a message is displayed prompting you to choose a program, select Nikon Transfer 2.

Windows 7

If the following dialog is displayed, select Nikon Transfer 2 as described below.

- 1 Under **Import pictures and videos**, click **Change program**. A program selection dialog will be displayed; select **Import File using Nikon Transfer 2** and click **OK**.



- 2 Double-click **Import file**.

3 Click Start Transfer.

At default settings, all the pictures on the memory card will be copied to the computer.



Click **Start Transfer**

4 Terminate the connection.

If the camera is connected to the computer, turn the camera off and disconnect the USB cable. If you are using a card reader or card slot, choose the appropriate option in the computer operating system to eject the removable disk corresponding to the memory card and then remove the card from the card reader or card slot.



Viewing Pictures

Pictures are displayed in ViewNX 2 when transfer is complete.

Starting ViewNX 2 Manually

- **Windows:** Double-click the ViewNX 2 shortcut on the desktop.
- **Mac:** Click the ViewNX 2 icon in the Dock.

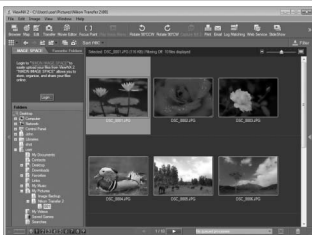

Retouching Photographs

To crop pictures and perform such tasks as adjusting sharpness and tone levels, click the **Edit** button in the toolbar.



Printing Pictures

Click the **Print** button in the toolbar. A dialog will be displayed, allowing you to print pictures on a printer connected to the computer.

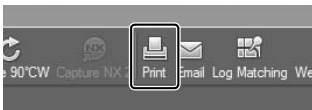

For More Information

Consult online help for more information on using ViewNX 2.

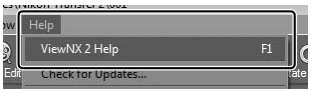

Technical Notes

Read this chapter for information on compatible accessories, cleaning and storing the camera, and what to do if an error message is displayed or you encounter problems using the camera.

Optional Accessories

At the time of writing, the following accessories were available for your camera.

Lenses	1 mount lenses
Mount adapters	Mount Adapter FT1
Electronic viewfinders	Electronic Viewfinder DF-N1000 (□ 27): The DF-N1000 connects to the camera multi accessory port.
Grips	Grip GR-N1010 (□ 29): The GR-N1010 offers improved handling and is equipped with a sub-command dial and shutter-release and Fn3 buttons.
Power sources	<ul style="list-style-type: none">• Rechargeable Li-ion Battery EN-EL20a (□ 20–21): Additional EN-EL20a batteries are available from local retailers and Nikon-authorized service representatives.• Battery Charger MH-29 (□ 20): Recharge EN-EL20a batteries.• Power Connector EP-5C, AC Adapter EH-5b: These accessories can be used to power the camera for extended periods (EH-5a and EH-5 AC adapters can also be used). An EP-5C power connector is required to connect the camera to the EH-5b, EH-5a, or EH-5.

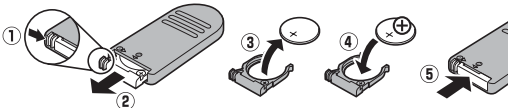
Flash units	<p>When mounted on the Nikon 1 V3, the following flash units support i-TTL and manual flash control.</p> <ul style="list-style-type: none"> • Speedlight SB-N5: The SB-N5 has a Guide Number of 8.5/27.9 (m/ft, ISO 100, 20 °C/68 °F; Guide Number at ISO 160 is 10.8/35.4). • Speedlight SB-N7: The SB-N7 has a Guide Number of 18/59 (m/ft, ISO 100, 20 °C/68 °F; Guide Number at ISO 160 is 22.8/74.8).
Remote controls	<p>Wireless Remote Control ML-L3 (☞ 79): The ML-L3 uses a 3 V CR2025 battery.</p>  <p>Pressing the battery-chamber latch to the right (①), insert a fingernail into the gap and open the battery chamber (②). Ensure that the battery is in the correct orientation (④).</p>
Micro-phones	<p>Stereo Microphone ME-1: Connect the ME-1 to the camera microphone jack to record stereo sound while reducing the noise caused by lens vibration being recorded during autofocus.</p>
Multi accessory port accessories	<p>Multi Accessory Port Adapter AS-N1000: The AS-N1000 fixes optional ME-1 stereo microphones to the Nikon 1 V3.</p>
GPS units	<p>GPS Unit GP-N100: Record the time (UTC) and the camera's current latitude, longitude, and altitude with every picture taken. Note that the built-in flash can not be used when the GP-N100 is attached.</p>
Body caps	<p>Body Cap BF-N1000: The body cap keeps the image sensor free of dust when a lens is not in place.</p>

Optional Accessories

Availability may vary with country or region. See our website or brochures for the latest information.

Approved Memory Cards

The following cards have been tested and approved for use in the camera. Cards with class 6 or faster write speeds are recommended for movie recording. Recording may end unexpectedly when cards with slower write speeds are used.

	microSD cards	microSDHC cards ²	microSDXC cards ³
SanDisk	2 GB ¹	4 GB, 8 GB, 16 GB, 32 GB	64 GB
Toshiba			—
Panasonic			—

- 1** Check that any card readers or other devices with which the card will be used support 2 GB cards.
- 2** Check that any card readers or other devices with which the card will be used are SDHC-compliant. The camera supports UHS-I.
- 3** Check that any card readers or other devices with which the card will be used are SDXC-compliant. The camera supports UHS-I.



Other cards have not been tested. For more details on the above cards, please contact the manufacturer.



Storage and Cleaning

Storage

If the camera will not be used for an extended period, remove the battery and store it in a cool, dry area with the terminal cover in place. To prevent mold or mildew, store the camera in a dry, well-ventilated area. Do not store your camera with naphtha or camphor moth balls or in locations that:

- are poorly ventilated or subject to humidities of over 60%
- are next to equipment that produces strong electromagnetic fields, such as televisions or radios
- are exposed to temperatures above +50 °C (122 °F) or below -10 °C (14 °F)

Cleaning

Camera body	Use a blower to remove dust and lint, then wipe gently with a soft, dry cloth. After using the camera at the beach or sea-side, wipe off sand or salt with a cloth lightly dampened in distilled water and dry thoroughly. Important: <i>Dust or other foreign matter inside the camera may cause damage not covered under warranty.</i>
Lens, viewfinder	These elements are easily damaged. Remove dust and lint with a blower. If using an aerosol blower, keep the can vertical to prevent the discharge of liquid. To remove fingerprints and other stains, apply a small amount of lens cleaner to a soft cloth and clean with care.
Monitor	Remove dust and lint with a blower. When removing fingerprints and other stains, wipe the surface lightly with a soft cloth or chamois leather. Do not apply pressure, as this could result in damage or malfunction.

Do not use alcohol, thinner, or other volatile chemicals.



Caring for the Camera and Battery: Cautions

Do not drop: The product may malfunction if subjected to strong shocks or vibration.

Keep dry: This product is not waterproof, and may malfunction if immersed in water or exposed to high levels of humidity. Rusting of the internal mechanism can cause irreparable damage.

Avoid sudden changes in temperature: Sudden changes in temperature, such as those that occur when entering or leaving a heated building on a cold day, can cause condensation inside the device. To prevent condensation, place the device in a carrying case or plastic bag before exposing it to sudden changes in temperature.

Keep away from strong magnetic fields: Do not use or store this device in the vicinity of equipment that generates strong electromagnetic radiation or magnetic fields. Strong static charges or the magnetic fields produced by equipment such as radio transmitters could interfere with the display, damage data stored on the memory card, or affect the product's internal circuitry.

Keep the lens mount covered: Be sure to attach the body cap if the camera is without a lens.

Do not touch the image sensor: The image sensor is easily damaged. Under no circumstances should you exert pressure on the sensor, poke it with cleaning tools, or subject it to powerful air currents from a blower. These actions could scratch or otherwise damage the sensor.

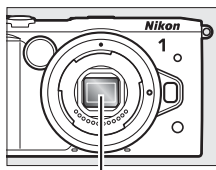

Image sensor

Turn the product off before removing or disconnecting the power source: Do not unplug the product or remove the battery while the product is on or while images are being recorded or deleted. Forcibly cutting power in these circumstances could result in loss of data or in damage to product memory or internal circuitry. To prevent an accidental interruption of power, avoid carrying the product from one location to another while the AC adapter is connected.



Cleaning: When cleaning the camera body, use a blower to gently remove dust and lint, then wipe gently with a soft, dry cloth. After using the camera at the beach or seaside, wipe off any sand or salt using a cloth lightly dampened in pure water and then dry the camera thoroughly.

Lenses, viewfinders, and other glass elements are easily damaged. Dust and lint should be gently removed with a blower. When using an aerosol blower, keep the can vertical to prevent discharge of liquid. To remove fingerprints and other stains from the glass, apply a small amount of glass cleaner to a clean, soft cloth and wipe the lens carefully.

Storage: To prevent mold or mildew, store the camera in a cool, dry, well-ventilated area. If you are using an AC adapter, unplug the adapter to prevent fire. If the product will not be used for an extended period, remove the battery to prevent leakage and store the camera in a plastic bag containing a desiccant. Do not, however, store the camera case in a plastic bag, as this may cause the material to deteriorate. Note that desiccant gradually loses its capacity to absorb moisture and should be replaced at regular intervals.

To prevent mold or mildew, take the camera out of storage at least once a month. Turn the camera on and release the shutter a few times before putting it away.

Store the battery in a cool, dry place. Replace the terminal cover before putting the battery away.

Notes on the monitor and viewfinder: These displays are constructed with extremely high precision; at least 99.99% of pixels are effective, with no more than 0.01% being missing or defective. Hence while these displays may contain pixels that are always lit (white, red, blue, or green) or always off (black), this is not a malfunction and has no effect on images recorded with the device.

Images in the monitor may be difficult to see in a bright light.

Do not apply pressure to the display, as this could cause damage or malfunction. Dust or lint on the display can be removed with a blower. Stains can be removed by wiping lightly with a soft cloth or chamois leather. Should the monitor break, care should be taken to avoid injury from broken glass and to prevent liquid crystal from the display touching the skin or entering the eyes and mouth.



Do not leave the lens pointed at the sun:

Do not leave the lens pointed at the sun or other strong light source for an extended period. Intense light may cause the image sensor to deteriorate or produce a white blur effect in photographs.

Moiré: Moiré is an interference pattern created by the interaction of an image containing a regular, repeating grid, such as the pattern of weave in cloth or windows in a building, with the camera image sensor grid. In some cases, it may appear in the form of lines. If you notice moiré in your photographs, try changing the distance to the subject, zooming in and out, or changing the angle between the subject and the camera.

Lines: Noise in the form of lines may in rare cases appear in pictures of extremely bright or backlit subjects.

Batteries: Batteries may leak or explode if improperly handled. Observe the following precautions when handling batteries:

- Use only batteries approved for use in this equipment.
- Do not expose the battery to flame or excessive heat.
- Keep the battery terminals clean.
- Turn the product off before replacing the battery.

- Do not use the battery at ambient temperatures below 0°C (32°F) or above 40°C (104°F); failure to observe this precaution could damage the battery or impair its performance. Capacity may be reduced and charging times may increase at battery temperatures from 0°C (32°F) to 10°C (50°F) and from 45°C (113°F) to 60°C (140°F); the battery will not charge if its temperature is below 0°C (32°F) or above 60°C (140°F).
- Remove the battery from the camera or charger when not in use and replace the terminal cover. These devices draw minute amounts of charge even when off and could draw the battery down to the point that it will no longer function. If the battery will not be used for some time, insert it in the camera and run it flat before removing it and storing it in a location with an ambient temperature of 15 °C to 25 °C (59 °F to 77 °F; avoid hot or extremely cold locations). Repeat this process at least once every six months.
- Turning the camera on and off repeatedly when the battery is fully discharged will shorten battery life. Batteries that have been fully discharged must be charged before use.



- The internal temperature of the battery may rise while the battery is in use. Attempting to charge the battery while the internal temperature is elevated will impair battery performance, and the battery may not charge or charge only partially. Wait for the battery to cool before charging.
- Continuing to charge the battery after it is fully charged can impair battery performance.
- A marked drop in the time a fully charged battery retains its charge when used at room temperature indicates that it requires replacement. Purchase a new EN-EL20a battery.
- Charge the battery before use. When taking photographs on important occasions, ready a spare EN-EL20a battery and keep it fully charged. Depending on your location, it may be difficult to purchase replacement batteries on short notice. Note that on cold days, the capacity of batteries tends to decrease. Be sure the battery is fully charged before taking photographs outside in cold weather. Keep a spare battery in a warm place and exchange the two as necessary. Once warmed, a cold battery may recover some of its charge.
- Used batteries are a valuable resource; recycle in accord with local regulations.

The battery charger: Charge the battery at ambient temperatures between 5°C (41°F) and 35°C (95°F). If the **CHARGE** lamp flashes quickly during charging, cease use immediately and take battery and charger to your retailer or a Nikon-authorized service representative.

Do not move the charger or touch the battery during charging. Failure to observe this precaution could in very rare instances result in the charger showing that charging is complete when the battery is only partially charged. Remove and reinsert the battery to begin charging again.

Use the charger with compatible batteries only. Unplug when not in use.

Memory Cards:

- Do not remove memory cards from the camera, turn the camera off, or remove or disconnect the power source during formatting or while data are being recorded, deleted, or copied to a computer. Failure to observe these precautions could result in loss of data or in damage to the camera or card.
- Do not touch the card terminals with your fingers or metal objects.



- Do not bend, drop, or subject to strong physical shocks.
- Do not apply force to the card casing. Failure to observe this precaution could damage the card.
- Do not expose to water, heat, high levels of humidity, or direct sunlight.
- Do not format memory cards in a computer.

Servicing the Camera and Accessories

The camera is a precision device and requires regular servicing. Nikon recommends that the camera be inspected by the original retailer or Nikon-authorized service representative once every one to two years, and that it be serviced once every three to five years (note that fees apply to these services). Frequent inspection and servicing are particularly recommended if the camera is used professionally. Any accessories regularly used with the camera, such as lenses, should be included when the camera is inspected or serviced.



Troubleshooting

If the camera fails to function as expected, check this list of common problems before consulting your retailer or Nikon representative.

Battery/Display

The camera is on but does not respond: Wait for recording or any other processing to end. If the problem persists, turn the camera off. If the camera still does not respond, remove and replace the battery or disconnect and reconnect the AC adapter, but note that this will delete any data not yet saved. Data already saved to the memory card are unaffected.

The displays are off:

- The camera is off (☞ 24) or the battery is exhausted (☞ 4, 20).
 - An object has come close to the eye sensor, turning the optional viewfinder on and the monitor off (☞ 28).
 - The displays have turned off automatically to save power (☞ 24). The displays can be reactivated by pressing the shutter-release button.
 - The camera is connected to a computer (☞ 106) or television.
-

The viewfinder is out of focus: Focus the viewfinder using the diopter adjustment control (☞ 28).

The camera turns off without warning:

- The battery is low (☞ 4, 20).
 - The display has turned off automatically to save power (☞ 24). The display can be reactivated by pressing the shutter-release button.
 - The camera's internal temperature is high (☞ xii, 123). Wait for the camera to cool before turning it on again.
-

Indicators are not displayed: Press the DISP button (☞ 5).



Shooting (All Modes)

The camera takes time to turn on: Delete files or format the memory card.

The shutter-release is disabled:

- The battery is exhausted (☐ 4, 20).
 - The memory card is full.
 - The flash is charging (☐ 83).
 - The camera is not in focus (☐ 33).
 - You are currently filming a slow-motion movie (☐ 52).
-

Only one picture is taken each time the shutter-release button is pressed in continuous release mode:  is selected in continuous mode (☐ 75) and flash lighting is used.

No photo taken when ML-L3 remote control shutter-release button is pressed:

- Replace battery in remote control (☐ 110).
 - Choose a remote control mode (☐ 79).
 - The remote control standby timer has expired (☐ 102).
 - The remote is not pointed at the camera or the infrared receiver is not visible (☐ 2, 80).
 - The remote is too far from the camera (☐ 80).
 - Bright light is interfering with remote.
-

Smudges appear in photographs: Clean the front and rear lens elements.

Flicker or banding appears in movies or in the display: Choose a **Flicker reduction** setting that matches the local AC power supply (☐ 102).

No flash: The built-in flash and optional flash units will not fire during movie recording (☐ 48) or live image control (☐ 37), in best moment capture (☐ 61), Motion Snapshot (☐ 71), advanced movie (☐ 51), creative palette (☐ 41), or easy panorama (☐ 43) modes, or when HDR is on (☐ 42), a frame rate of 10 fps or higher is selected in continuous mode (☐ 75), or **6400 (NR)** or **12800 (NR)** is selected for ISO sensitivity (☐ 101).

Menu items are unavailable: Some options are only available in particular shooting or exposure modes.



Movies

Cannot record movies: The movie-record button can not be used to record movies in best moment capture or Motion Snapshot mode (☞ 64, 73).

No sound is recorded for movies:

- **Microphone off** is selected for **Movie sound options > Microphone** (☞ 101).
- Live audio is not recorded with slow-motion, fast-motion, or jump-cut movies (☞ 51) or with Motion Snapshots recorded with **None** selected for **Audio** (☞ 73).

Tap Shooting Options

The touch screen can not be used for shooting or focus:

- Touch shooting options are not available in best moment capture or Motion Snapshot mode.
- The edges of the display can not be used for shooting or focus. Tap closer to the center of the display.

Pictures are blurred: The camera may move when the display is tapped, which may under some conditions result in blurred pictures. Use both hands to hold the camera steady.

Playback

“Tall” (portrait) orientation photos are displayed in “wide” (landscape) orientation:

- Select **On** for **Rotate tall** (☞ 98).
- The photos were taken with **Auto image rotation** off (☞ 102).
- Camera was pointed up or down when the photo was taken.
- Photo is displayed in image review.

Cannot hear movie sound:

- Rotate the main command dial right to raise the volume (☞ 53). If the camera is connected to a television, use the controls for the TV to adjust the volume.
- You are blocking the speaker with a finger or other object (☞ 3). Remove the obstruction.
- Live audio is not recorded with slow-motion, fast-motion, or jump-cut movies (☞ 51) or with Motion Snapshots recorded with **None** selected for **Audio** (☞ 73).

Cannot delete images: Remove protection from the files before deletion (☞ 98).



Wi-Fi (Wireless Networks)

Smart devices do not display the camera SSID (network name):

- Confirm that camera Wi-Fi is enabled (📖 89).
- Try turning the smart device Wi-Fi off and then on again.

Miscellaneous

The date of recording is not correct: Set the camera clock (📖 102).

Menu items are unavailable: Some options are only available at particular settings or when a memory card is inserted.



Error Messages

This section lists the error messages that appear in the display.

Message	Solution
(Shutter-speed or aperture display flashes)	If the subject is too bright, lower ISO sensitivity or choose a faster shutter speed or smaller aperture (higher f-number). If the subject is too dark, raise ISO sensitivity, use a flash, or choose a slower shutter speed or larger aperture (lower f-number).
Keeping the zoom ring button pressed, rotate the zoom ring to extend the lens.	A lens with a retractable lens barrel button is attached with the lens barrel retracted. Keeping the retractable lens barrel button pressed, rotate the zoom ring to extend the lens.
Check lens. Pictures can only be taken when a lens is attached.	Attach a lens.
Lens error. Try again after turning the camera off and on.	Turn the camera off and then on again. If the problem persists or reoccurs frequently, contact a Nikon-authorized service representative.
The clock has been reset.	Set the camera clock.
No memory card.	Turn the camera off and confirm that the card is correctly inserted.
This memory card cannot be used. Card may be damaged; insert a different card.	<ul style="list-style-type: none">• Use an approved card.• Format the card. If the problem persists, the card may be damaged. Contact a Nikon-authorized service representative.• Insert a new memory card.



Message	Solution
This memory card is not formatted. Format the memory card?	Select Yes to format the card, or turn the camera off and insert another memory card.
Memory card is full.	<ul style="list-style-type: none"> • You may be able to record additional images if you reduce image quality or size. • Delete unwanted images. • Insert another memory card.
Cannot create additional folders on memory card.	If the current folder is numbered 999 and contains either 999 photographs or a photograph numbered 9999, the shutter-release button will be disabled and no further photographs can be taken. Choose Yes for Reset file numbering and then either format the current memory card or insert a new memory card.
The movie-record button cannot be used in this mode.	The movie-record button can not be used in best moment capture or Motion Snapshot modes.
Photographs cannot be recorded in this mode.	The shutter-release button can not be used to take photographs while a slow-motion movie is being recorded.
The camera's internal temperature is high. The camera will now turn off.	Wait for the camera to cool.
Memory card contains no images.	To view pictures, insert a memory card containing images.
Cannot display this file.	The file has been created or modified on a computer or different make of camera, or is corrupt.





Specifications

Nikon 1 V3 Digital Camera

Type	
Type	Digital camera with support for interchangeable lenses
Lens mount	Nikon 1 mount
Effective angle of view	Approx. 2.7× lens focal length (35 mm format equivalent)
Effective pixels	18.4 million
Image sensor	
Image sensor	13.2 mm × 8.8 mm CMOS sensor (Nikon CX format)
Dust-reduction system	Image sensor cleaning
Storage	
Image size (pixels)	Still images taken in auto, P, S, A, M, best moment capture, and all creative modes other than easy panorama (aspect ratio 3 : 2)
	• 5232 × 3488
	• 3920 × 2616
	• 2608 × 1744
	Still images taken in normal panorama mode with camera panned horizontally (aspect ratio 120 : 23)
	• 4800 × 920
	Still images taken in normal panorama mode with camera panned vertically (aspect ratio 8 : 25)
	• 1536 × 4800
	Still images taken in wide panorama mode with camera panned horizontally (aspect ratio 240 : 23)
	• 9600 × 920
	Still images taken in wide panorama mode with camera panned vertically (aspect ratio 4 : 25)
	• 1536 × 9600
Still images taken during movie recording (aspect ratio 3 : 2)	
• 5232 × 3488 (1080/60p, 1080/30p)	
• 1472 × 984 (720/60p, 720/30p)	
Motion Snapshots (photo portion, aspect ratio 16 : 9)	
• 5232 × 2936	

File format	<ul style="list-style-type: none"> • NEF (RAW): 12-bit, compressed • JPEG: JPEG-Baseline compliant with fine (approx. 1 : 4), normal (approx. 1 : 8) compression • NEF (RAW) + JPEG: Single photograph recorded in both NEF (RAW) and JPEG formats
Picture Control system	Standard, Neutral, Vivid, Monochrome, Portrait, Landscape; selected Picture Control can be modified; storage for custom Picture Controls
Media	microSD (micro Secure Digital), microSDHC, and microSDXC memory cards
File system	DCF 2.0, DPOF, Exif 2.3, PictBridge
Shooting modes	auto; creative, with a choice of the following options: creative palette, HDR, easy panorama, soft, miniature effect, selective color, cross process, and toy camera effect; programmed auto with flexible program, shutter-priority auto, aperture-priority auto, and manual; best moment capture (Active Selection, slow view and Smart Photo Selector); advanced movie (HD movie, slow motion, jump cut, fast motion and 4-second movie), Motion Snapshot
Shutter	
Type	Electronically-controlled vertical-travel focal-plane mechanical shutter; electronic shutter
Speed	<ul style="list-style-type: none"> • Mechanical shutter: $\frac{1}{4000}$–30 s in steps of $\frac{1}{3}$ EV; Bulb; Time (requires optional ML-L3 remote control) • Electronic shutter: $\frac{1}{16,000}$–30 s in steps of $\frac{1}{3}$ EV; Bulb; Time (requires optional ML-L3 remote control) <p>Note: Bulb and Time end automatically after approximately 2 minutes</p>



Flash sync speed	<ul style="list-style-type: none"> • Mechanical shutter: Synchronizes with shutter at $X=1/250$ s or slower • Electronic shutter: Synchronizes with shutter at $X=1/60$ s or slower
Release	
Mode	<ul style="list-style-type: none"> • Single frame, continuous • Self-timer, remote, interval timer shooting
Frame advance rate	Approx. 6, 10, 20, 30, or 60 fps
Self-timer	2 s, 10 s
Remote control modes	Delayed remote (2 s); quick-response remote
Exposure	
Metering	TTL metering using image sensor
Metering method	<ul style="list-style-type: none"> • Matrix • Center-weighted: Meters 4.5 mm circle in center of frame • Spot: Meters 2 mm circle centered on selected focus area
Mode	P programmed auto with flexible program; S shutter-priority auto; A aperture-priority auto; M manual;  scene auto selector
Exposure compensation	-3–+3 EV in increments of $1/3$ EV
Exposure lock	Luminosity locked at metered value with  (AE-L/AF-L) button
ISO sensitivity (Recommended Exposure Index)	ISO 160; ISO 200–12800 in steps of 1 EV; 6400 (NR); 12800 (NR); auto ISO sensitivity control (ISO 160–6400, 160–3200, 160–800) available (user controlled in P, S, A, and M modes)
Active D-Lighting	On, off



Focus	
Autofocus	Hybrid autofocus (phase-detection/contrast-detect AF); AF-assist illuminator
Lens servo	<ul style="list-style-type: none"> • Autofocus (AF): Single AF (AF-S); continuous AF (AF-C); auto AF-S/AF-C selection (AF-A); full-time AF (AF-F) • Manual focus (MF)
AF-area mode	Single-point, auto-area, subject tracking
Focus area	<ul style="list-style-type: none"> • Single-point AF: 171 focus areas; the center 105 areas support phase-detection AF • Auto-area AF: 41 focus areas
Focus lock	Focus can be locked by pressing shutter-release button halfway (single AF) or by pressing AE-L/AF-L (AE-L/ AF-L) button
Face priority	On, off
Flash	
Built-in flash	Raised by pressing flash button
Guide Number (GN)	Approx. 5/16 (m/ft, ISO 100, 20 °C/68 °F; at ISO 160, Guide Number is approx. 6.3/20.7)
Control	i-TTL flash control using image sensor
Mode	Fill flash, fill flash + slow sync, red-eye reduction, red-eye reduction + slow sync, rear-curtain sync, rear curtain + slow sync
Flash compensation	-3 – +1 EV in increments of 1/3 EV
Flash-ready indicator	Lights when flash is fully charged
White balance	Auto, incandescent, fluorescent, direct sunlight, flash, cloudy, shade, preset manual, all except preset manual with fine tuning



Movie	
Metering	TTL metering using image sensor
Metering method	<ul style="list-style-type: none"> • Matrix • Center-weighted: Meters 4.5 mm circle in center of frame • Spot: Meters 2 mm circle centered on selected focus area
Frame size (pixels)/ recording rate	HD movies (aspect ratio 16 : 9)
	<ul style="list-style-type: none"> • 1920 × 1080/60p (59.94 fps) • 1920 × 1080/30p (29.97 fps) • 1280 × 720/60p (59.94 fps) • 1280 × 720/30p (29.97 fps)
	Slow-motion movies
	<ul style="list-style-type: none"> • 1280 × 720/120 fps (aspect ratio 16 : 9; plays at 30p/29.97 fps) • 768 × 288/400 fps (aspect ratio 8 : 3; plays at 30p/29.97 fps) • 416 × 144/1200 fps (aspect ratio 26 : 9; plays at 30p/29.97 fps)
	Fast-motion, jump-cut, and 4-second movies (aspect ratio 16 : 9)
	1920 × 1080/30p (29.97 fps)
	Motion Snapshots (movie portion, aspect ratio 16 : 9)
	1920 × 1080/60p (59.94 fps) (plays at 24p/23.976 fps)
File format	MOV
Video compression	H.264/MPEG-4 Advanced Video Coding
Audio recording format	PCM
Audio recording device	Built-in or optional external ME-1 stereo microphone; sensitivity adjustable
Monitor	
	7.5 cm (3-in.), approx. 1037k-dot, TFT vari-angle LCD touch screen with brightness and angle adjustment
Playback	
	Full-frame and thumbnail (4, 9, or 16 images or calendar) playback with playback zoom, movie and panorama playback, slide show, histogram display, auto image rotation, and rating option



Interface	
USB	Hi-Speed USB
HDMI output	Type D HDMI connector
Multi accessory port	Used for designated accessories
Audio input	Stereo mini-pin jack (3.5mm diameter)
Wireless	
Standards	IEEE 802.11b, IEEE 802.11g
Communications protocols	<ul style="list-style-type: none"> • IEEE 802.11b: DSSS/CCK • IEEE 802.11g: OFDM
Operating frequency	2412–2462 MHz (channels 1–11)
Range (line of sight)	Approximately 10 m/33 ft (assumes no interference; range may vary with signal strength and presence or absence of obstacles)
Data rate	54 Mbps Maximum logical data rates according to IEEE standard. Actual rates may differ.
Security	<ul style="list-style-type: none"> • Authentication: Open system, WPA2-PSK • Encryption: AES
Wireless setup	Supports WPS
Access protocols	Infrastructure
Supported languages	
	Arabic, Bengali, Bulgarian, Chinese (Simplified and Traditional), Czech, Danish, Dutch, English, Finnish, French, German, Greek, Hindi, Hungarian, Indonesian, Italian, Japanese, Korean, Marathi, Norwegian, Persian, Polish, Portuguese (European and Brazilian), Romanian, Russian, Serbian, Spanish, Swedish, Tamil, Telugu, Thai, Turkish, Ukrainian, Vietnamese
Power source	
Battery	One rechargeable Li-ion EN-EL20a battery
AC adapter	EH-5b AC adapter; requires EP-5C power connector (available separately)
Tripod socket	
	1/4-in. (ISO 1222)



Dimensions/weight	
Dimensions (W × H × D)	Approx. 110.9 × 65.0 × 33.2 mm (4.4 × 2.6 × 1.3 in.), excluding projections
Weight	Approx. 324 g (11.4 oz) with battery and memory card but without body cap; approx. 282 g (9.9 oz), camera body only

Operating environment	
Temperature	0 °C–40 °C (+32 °F–104 °F)
Humidity	85% or less (no condensation)

- Unless otherwise stated, all figures are for a camera with a fully-charged battery operating at the temperature specified by the Camera and Imaging Products Association (CIPA): 23 ±3 °C (73.4 ±5.4 °F).
- Nikon reserves the right to change the specifications of the hardware and software described in this manual at any time and without prior notice. Nikon will not be held liable for damages that may result from any mistakes that this manual may contain.

MH-29 battery charger	
Rated input	AC 100–240 V, 50–60 Hz, 0.2 A
Rated output	DC 8.4 V/0.6 A
Supported batteries	Nikon EN-EL20a rechargeable Li-ion batteries
Charging time	Approx. 3 hours at an ambient temperature of 25 °C (77 °F) when no charge remains
Operating temperature	0 °C–40 °C (+32 °F–104 °F)
Dimensions (W × H × D)	Approx. 67.0 × 28.0 × 94.0 mm (2.6 × 1.1 × 3.7 in.), excluding plug adapter
Weight	Approx. 83 g (2.9 oz), excluding plug adapter

EN-EL20a rechargeable Li-ion battery	
Type	Rechargeable lithium-ion battery
Rated capacity	7.2 V, 1110 mAh
Operating temperature	0 °C–40 °C (+32 °F–104 °F)
Dimensions (W × H × D)	Approx. 30.7 × 50.0 × 14.0 mm (1.2 × 2.0 × 0.6 in.)
Weight	Approx. 42 g (1.5 oz), excluding terminal cover

1 NIKKOR VR 10–30mm f/3.5–5.6 PD-ZOOM

Type	1 mount lens
Focal length	10–30 mm
Maximum aperture	f/3.5–5.6
Construction	9 elements in 7 groups (including 4 aspherical lens elements, 1 ED lens element, and HRI lens elements)
Angle of view	77°–29° 40'
Vibration reduction	Lens shift using voice coil motors (VCMs)
Minimum focus distance	0.2 m (0.7 ft) from focal plane at all zoom positions
Diaphragm blades	7 (rounded diaphragm opening)
Diaphragm	Fully automatic
Aperture range	<ul style="list-style-type: none">• 10 mm focal length: f/3.5–16• 30 mm focal length: f/5.6–16
Dimensions	Approx. 58 mm diameter × 28 mm (distance from camera lens mount flange when lens is retracted)
Weight	Approx. 85 g (3.0 oz)

1 NIKKOR 11–27.5mm f/3.5–5.6

Type	1 mount lens
Focal length	11–27.5 mm
Maximum aperture	f/3.5–5.6
Construction	8 elements in 6 groups (including 1 ED lens element and 1 aspherical lens element), 1 protective glass element
Angle of view	72°–32° 20'
Minimum focus distance	0.3 m (1.0 ft) from focal plane at all zoom positions
Diaphragm blades	7 (rounded diaphragm opening)
Diaphragm	Fully automatic
Aperture range	<ul style="list-style-type: none">• 11 mm focal length: f/3.5–16• 27.5 mm focal length: f/5.6–16
Filter-attachment size	40.5 mm (P=0.5 mm)
Dimensions	Approx. 57.5 mm diameter × 31 mm (distance from camera lens mount flange when lens is retracted)
Weight	Approx. 83 g (3.0 oz)



DF-N1000 Electronic Viewfinder

Type	0.48-in., approx. 2359k-dot color TFT LCD viewfinder with diopter control and brightness adjustment
Frame coverage	Approx. 100% horizontal and 100% vertical
Eyepoint	16 mm (-1.0 m^{-1} ; from viewfinder eyepiece protective glass)
Diopter adjustment	-3 – $+1 \text{ m}^{-1}$
Eye sensor	Camera switches to viewfinder display when it detects that viewfinder is in use
Operating temperature	0 °C–40 °C (+32 °F–104 °F)
Dimensions (W × H × D)	Approx. 32.5 × 33.7 × 40.8 mm (1.3 × 1.3 × 1.6 in.), excluding projections
Weight	Approx. 26 g (0.9 oz), excluding connector cover

GR-N1010 Grip

Operating temperature	0 °C–40 °C (+32 °F–104 °F)
Dimensions (W × H × D)	Approx. 119.2 × 76.6 × 48.8 mm (4.7 × 3.0 × 1.9 in.), excluding projections
Weight	Approx. 63 g (2.2 oz), excluding connector cap

Specifications subject to change without notice. Nikon will not be held liable for damages that may result from any mistakes that this manual may contain.



Trademark Information

Mac and OS X are registered trademarks of Apple Inc. in the United States and/or other countries. Microsoft, Windows, and Windows Vista are either registered trademarks, or trademarks of Microsoft Corporation in the United States and/or other countries. The PictBridge logo is a trademark. The microSD, microSDHC, and microSDXC logos are trademarks of SD-3C, LLC. HDMI, the HDMI logo and High-Definition Multimedia Interface are trademarks or registered trademarks of HDMI Licensing LLC.

HDMI

Wi-Fi and the Wi-Fi logo are trademarks or registered trademarks of the Wi-Fi Alliance. All other trade names mentioned in this manual or the other documentation provided with your Nikon product are trademarks or registered trademarks of their respective holders.

FreeType License (FreeType2)

Portions of this software are copyright © 2012 The FreeType Project (<http://www.freetype.org>). All rights reserved.

MIT License (HarfBuzz)

Portions of this software are copyright © 2014 The HarfBuzz Project (<http://www.freedesktop.org/wiki/Software/HarfBuzz>). All rights reserved.



Battery Life

The number of shots or movie footage that can be recorded with fully-charged batteries varies with the condition of the battery, temperature, the interval between shots, and the length of time menus are displayed. Sample figures for EN-EL20a (1110 mAh) batteries are given below.

- **Still images: Approximately 310 shots**
- **Movies: Approximately 75 minutes at 1080/60p**

Measured according to CIPA standards at 23 ± 3 °C (73.4 ± 5.4 °F) with the camera at default settings, a fully-charged battery, a 1 NIKKOR VR 10-30mm f/3.5-5.6 PD-ZOOM lens, and a 16GB SanDisk SDSQXP-016G-J35 UHS-I microSDHC card. Value for still images obtained under the following test conditions: photographs taken at intervals of 30 s with the built-in flash fired with every other shot and the camera turned off and then on after every ten shots. Value for movies obtained under the following test conditions: a series of 10 minute movies with a file size of up to 4 GB were recorded; recording was only interrupted when temperature warning was displayed.

The following can reduce battery life:

- Keeping the shutter-release button pressed halfway
- Repeated autofocus operations
- Taking NEF (RAW) photographs
- Slow shutter speeds
- Using Wi-Fi
- Using vibration reduction mode with VR lenses
- Using zoom with power zoom lenses
- Using viewfinders, grips, flash units, or GPS units





























To ensure that you get the most from rechargeable Nikon EN-EL20a batteries:



- Keep the battery contacts clean. Soiled contacts can reduce battery performance.
- Use batteries immediately after charging. Batteries will lose their charge if left unused.



Index

Symbols

 (Auto mode)	7, 31
P (Programmed auto)	56
S (Shutter-priority auto)	57
A (Aperture-priority auto)	58
M (Manual)	59
 (Creative mode)	7, 39
 + (Advanced movie mode) ...	7, 48, 51
 (Best moment capture mode) .	7, 61
 (Motion Snapshot mode)	7, 71
 (Creative Palette)	40, 41
 (HDR)	40, 42
 (Easy panorama)	40, 43
 (Soft)	40
 (Miniature effect)	40
 (Selective color)	40, 46
 (Cross process)	40, 47
 (Toy camera effect)	40
 * (Portrait)	33
 (Landscape)	33
 * (Night portrait)	33
 * (Close up)	33
 * (Night landscape)	33
 * (Auto)	33
* (flexible program)	56
MENU (menu) button	8, 98
 (playback) button	35, 69, 74
 (delete) button	36, 54, 70, 74
 (OK) button	9
DISP (display) button	5
 (feature)	10
 (continuous shooting/self-timer) .	75, 77, 79
 (single frame)	76
 (continuous)	75
 (self-timer)	77
 (remote control)	79
 (flash mode)	82

 (red-eye reduction)	82
SLOW (slow sync)	82
REAR (rear-curtain sync)	82
 (flash-ready indicator)	83

Numerics

4-second movie	51
----------------------	----

A

AC adapter	109
Accessories	109
Active Selection	61
Advanced movie mode	7, 48, 51
Aperture	58, 59
Aperture-priority auto	58
Assign Fn buttons	12
Attaching the lens	22
Audio	73
Auto mode	31
Auto power off	24
Automatic scene selection	33

B

Battery	4, 20, 21, 130
Beep	33, 78
Best moment capture mode	61
Best shot	67, 69
Body cap	1, 2, 110
Buffering	63, 68, 72
Built-in flash	81

C

Charging a battery	20
Clock	25
Close up	33
Command dial	35, 56–59
Compatible lens	109
Computer	103
Continuous	75
Creative mode	39
Creative Palette	40, 41



Cross process 40, 47

D

Date and time 25

Date format 25

Daylight saving time 25

Delete 36, 54, 70, 74

Detailed display 4, 5

Detailed photo information 6

Diopter adjustment control 28

Display 5

E

Easy panorama 40, 43

Electronic viewfinder 27, 109

Exposure indicator 60

Eye sensor 28

F

Face priority 34

Fast motion 51

Fill flash 82

Flash 81

Flash mode 82

Flash range 84

Flash units 110

Flash-ready indicator 83

Flexible program 56

Fn button 12

Focal plane mark 2

Focus area 33

Focusing the viewfinder 28

Format memory card 21

Full-frame playback 35

G

Grid display 31

Grip 29, 109

H

H.264 128

HD movie 51

HDR 42

Hue (Cross process) 47

I

Infrared receiver 2, 80

Interval timer shooting 100

J

Jump cut 51

L

Landscape 33

Language 24

Lens 22, 32, 109, 131

Live image control 37

M

Manual 59

Maximum aperture 131

Memory card 21, 111

Memory card access lamp 34

Microphone 49

microSD card 111

Miniature effect 40

Mode dial 7

Monitor 4, 5, 13

Motion Snapshot mode 71

Mount adapter 109

Movie-record button 49

Movies 48, 51

Multi accessory port 27

N

Network connection 88

Night landscape 33

Night portrait 33

Nikon Transfer 2 107

P

Photo information 6

PIN-entry WPS 91

Playback 35

Portrait 33

Power connector 109

Power switch 24



Press the shutter-release button all the way down	34
Press the shutter-release button halfway	33
Programmed auto	56
Push-button WPS	90

R

Rear-curtain sync	82
Red-eye reduction	82
Remote control	79
Reset Wi-Fi settings	93
Retractable lens barrel button	23

S

Scene selection	33
Select color	46
Selective color	40, 46
Self-timer	77
Shooting mode	7
Shutter speed	57, 59
Shutter-priority auto	57
Shutter-release button	33
Simple photo information	6
Simplified display	5
Single frame	76
Size	124, 128
Slow motion	51
Slow sync	82
Slow view	65
Smart Photo Selector	67
Soft	40
Speaker	3
SSID	92
Strap	20
System requirements	104

T

Tap shooting options	85
Temperature warnings	xii
Time	25
Timer	77, 100
Touch screen	15, 85

Toy camera effect	40
-------------------------	----

U

USB	106
USB cable	106

V

Vari-angle monitor	3, 13
View SSID	92
Viewfinder	27, 109
ViewNX 2	103
Virtual horizon	5
Volume	53

W

Wi-Fi	xiv, 88
Wi-Fi upload	94, 98
Wireless	xiv, 88
Wireless Mobile Utility	88, 89

Z

Zoom ring	32
-----------------	----



No reproduction in any form of this manual, in whole or in part (except for brief quotation in critical articles or reviews), may be made without written authorization from NIKON CORPORATION.

